

BUNCHED BEAM CURRENT MEASUREMENTS WITH 100 pA RMS RESOLUTION AT CRYRING

A. Paal[#], A. Simonsson, Manne Siegbahn Laboratory, Stockholm, Sweden
J. Dietrich, I. Mohos, Forschungszentrum Jülich, Jülich, Germany

Abstract

In the 52 m circumference synchrotron CRYRING molecular beams with currents down to 1 nA are often used for experiments. To extend the rms resolution of the bunched beam current measurements down to 100 pA a Bergoz Integrating Current Transformer (ICT) and the sum signal from a capacitive pick-up (PU) are integrated simultaneously. Initially a high current is measured and the ICT signal is then used to calibrate the PU signal. The low noise PU signal can then be used to measure the current. The absolute calibration of the pick-up signal is obtained during 20-60 ms after the acceleration. For both detectors low noise amplifiers and differential input double integrators have been designed. A programmable phase shifter makes it possible to measure the beam current during the acceleration of the ions generating a gate signal for the integrators.

INTRODUCTION

The DC beam currents in CRYRING (typically 1nA to 10 μ A with positive and negative ions) are too low to be measured with a DC beam transformer. Beam intensity is therefore measured by radio frequency (rf) beam current measurements while the beam is bunched. The rf frequency ranges between 40 kHz to 1.5 MHz and the current pulse widths from 100 ns to 15 μ s with a 20-60% bunch duty cycle.

BEAM TRANSFORMER AND HEAD AMPLIFIER

The AC beam transformer is a capacitively shorted [1] Integrating Current Transformer (ICT) from Bergoz, type ICT-178-090-10:1. A low noise Wideband Amplifier has been constructed and placed close to the ICT to give a sensitivity of 4 V/A (Figure 1). The main parameters of the Wideband Amplifier are:

Gain:	80/60 dB
Noise (ICT + amplifier):	1 nV _{rms} /√Hz
Bandwidth:	10 kHz-10 MHz
Input Impedance:	200 Ω
Differential Outputs:	50 Ω

Transformer and Amplifier Noise Sources

It is easier to characterise the noise properties of the transformer and the amplifier in term of equivalent voltage noise sources. The equivalent circuit for the AC transformer and its head amplifier is shown in Figure 2.

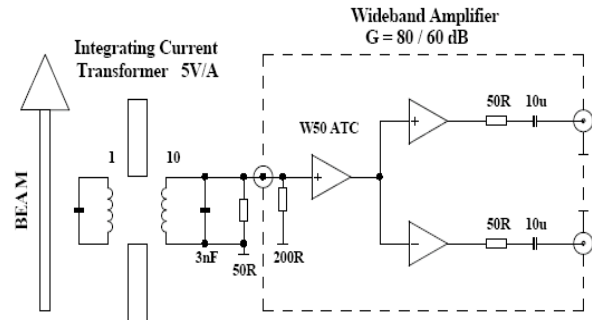

Figure 1: AC beam transformer and head amplifier.

Here I_b is the beam current, V_{na} [nV_{rms}/√Hz] and I_{na} [nA_{rms}/√Hz] are the amplifier voltage and current noise, respectively, C_p and C_s primary and secondary capacities of the transformer, respectively, and G is the amplifier gain. The Johnson voltage noise, V_p , of the shunt impedance, R_p , ($\sim 40 \Omega$) is 0.8 nV_{rms}/√Hz. The measured voltage noise at the outputs of the amplifier is less than 1 [nV_{rms}/√Hz]* G . The thermal noise from the shunt impedance, R_p , and the voltage noise from the first stage of the amplifier (type W50ATC) are the dominant noise sources. The current noise related to the input of the ICT is about 1 nA_{rms} @ bandwidth (BW) = 20 Hz [2].

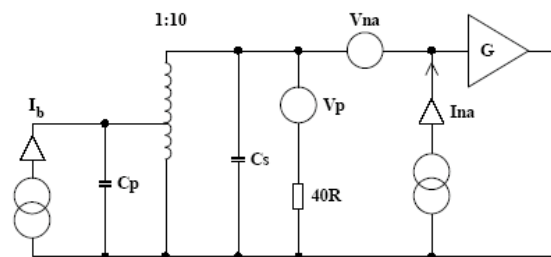

Figure 2: Equivalent circuit and noise sources.

Differential Input Double Integrator

A Differential Input Double Integrator has been designed with a high rejection for the gate signal in the full frequency range. It is controlled by an external trigger synchronised to the radio frequency. The Programmable Phase Shifter creates a gate signal with 33.3% duty cycle after an external trigger event for the baseline restorers. The two independent integrators consist of DC coupled buffer amplifiers, double cross coupled base line restorers (BLR), and continuous averaging circuits (Fig.3.).

Full Scale Range: $\pm 10 \text{ V}/\pm 10 \mu\text{A}$
 Differential Gain: 25
 Input Voltage Range: $\pm 4\text{V}$, DC coupled
 Gate Signal @ Output: $< 1 \text{ mV}$ (40 kHz-1.5 MHz)
 Long Time Drift: $< 1 \text{ mV}/8\text{hr}$
 Duty Cycle for BLR: 33.3%
 Output bandwidth: 100 Hz
 Gate Signal: TTL

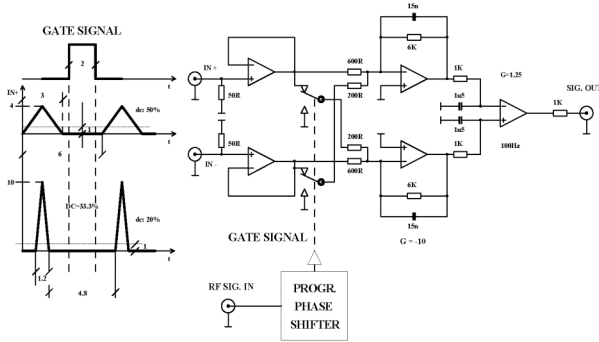

Figure 3: Block diagram of the Differential Input Double Integrator.

We have measured the noise and zero drift at the output of the Differential Input Double Integrator with a 20 Hz bandwidth without circulating beam in the ring. The ramp time was 1.1 s to the final frequency of 363 kHz. The current measuring window was 40 ms long at the flat top, 363 kHz, the background window was 320 ms long with radio frequency off. From the single measured points the standard deviation σ was calculated (Fig. 4.).

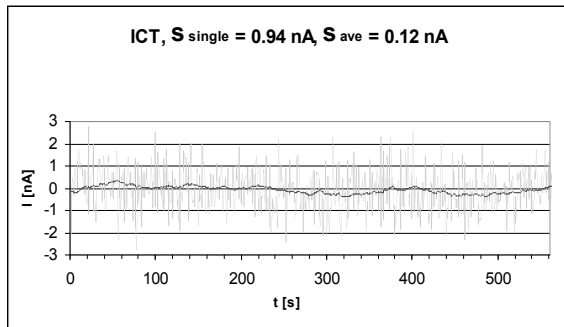

Figure 4: Noise and zero drift measurements at the output of the ICT integrator using 20 Hz low pass filter (LPF).

Programmable Phase Shifter

The phase shifter consists of a Direct-Digital Synthesis (DDS) oscillator controlled by a digital phase locked loop with programmable phase bias over a range of 2π . The accelerating main rf is applied to the reference input of the loop (Fig. 5.). The oscillator output tracks the reference frequency and phase with the programmed phase bias and the final shaper stage generates TTL gate pulses with a constant 33.3 % duty cycle over the full frequency range of 30 kHz-3 MHz. Commands and data between the host computer and the phase shifter unit are transferred via an isolated half-duplex serial connection.

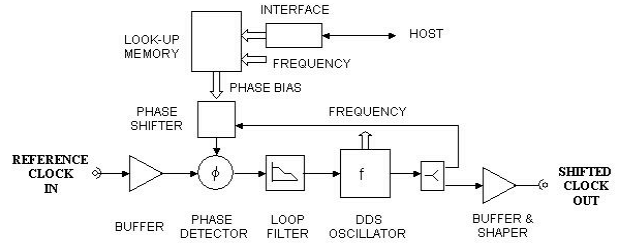

Figure 5: Block diagram of the Programmable Phase Shifter.

Version:	1.0	2.0
Frequency Range [MHz]:	0.03-3	0.03-5
Slew rate [MHz/s]:	0.15	20
Phase resolution [rad]:	< 0.02	< 0.01
Phase Range [rad]:	2π	2π

The proper phase relationship to the reference depends on the position of the current probe in the ring and the delays in the cables and electronics. The necessary phase bias will be calculated or measured at several frequencies. The control program generates the full range numeric function of the phase bias vs frequency by means of linear interpolation and stores these values in look-up memory. The phase shifter always uses the bias value corresponding to the actual reference frequency. The output pulses, applied to the gate input of the integrators, cover continuously the bunch pauses without overlapping with adjacent bunches at each frequencies of the acceleration ramp.

CAPACITIVE PICK-UP AND PREAMPLIFIER

The sensitivity of the current measurements, made with ICT, is limited to $1 \text{ nA}_{\text{rms}}$ by its 50Ω shunt resistor, thermal noise, and the rf background. To extend the rms resolution of the bunched beam current measurements down to 100 pA the signal from one of the capacitive pick-ups, amplified by a low noise module, is integrated simultaneously. This channel has a resolution of between 10 pA to 100 pA rms over the frequency range 40 kHz - 1.5 MHz. The bunched beam current monitoring system is shown in Fig. 6.

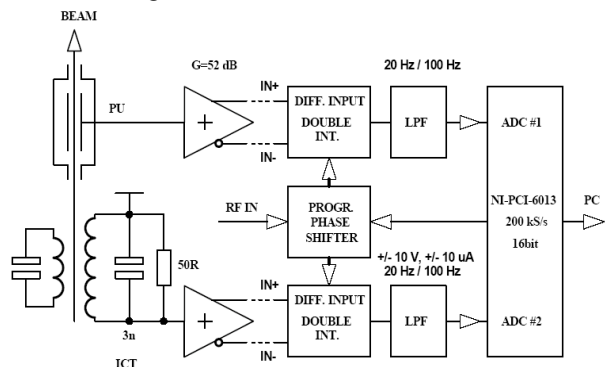

Figure 6: Bunched beam current monitoring system of CRYRING.

Pick-up Amplifier

The preamplifier input circuit consists of two FETs, type 2SK300 (Fig. 7), connected in parallel [3]. The equivalent input noise is $5 \mu\text{V}_{\text{rms}}$ @ 10 MHz BW. The output signal of the PU amplifier ($G=52 \text{ dB}$) and the related gate signal are shown in Fig. 8.

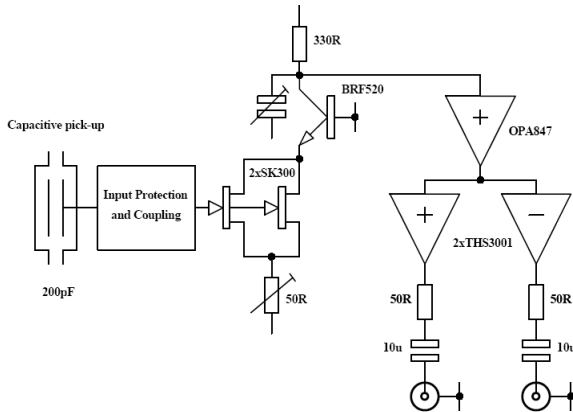

Figure 7: Capacitive pick-up preamplifier.

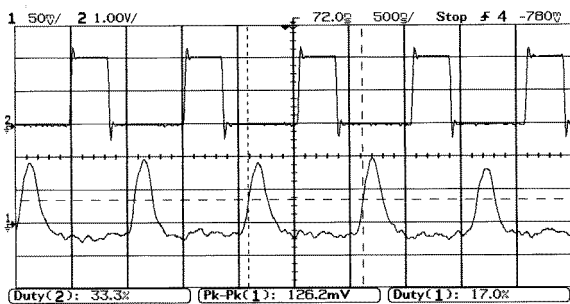

Figure 8: Gate signal for the baseline restoration with 33.3% duty cycle and capacitive pick-up signal.

CURRENT MEASUREMENTS AND CALIBRATION

The amplified signal of the Integrating Current Transformer (ICT) and the sum signal from a capacitive pick-up (PU) are integrated by two similar Differential Input Double Integrators (Fig. 6.).

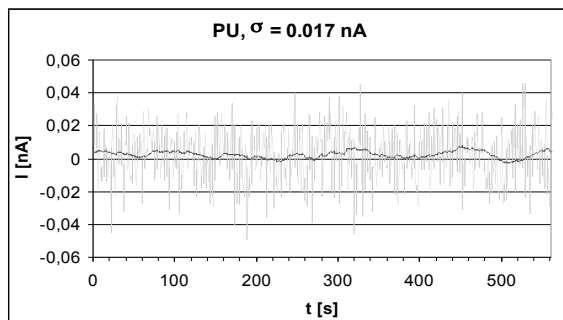

Figure 9: Noise and zero drift measurements at the output of the PU integrator using 20 Hz LPF.

At CRYRING, before an absolute ion current is obtained, a background measurement is taken under the same conditions, i.e. same trigger frequency, rf amplitude, magnet ramping scheme etc, but without the circulating beam (Fig. 4, 9). An absolute calibration of the pick-up channel is obtained during 20-60 ms after the acceleration using 100 individual measurements of the ICP and PU channels. A 10 nA current measurement made with the Bunched beam current monitoring system at CRYRING is shown in Fig. 10.

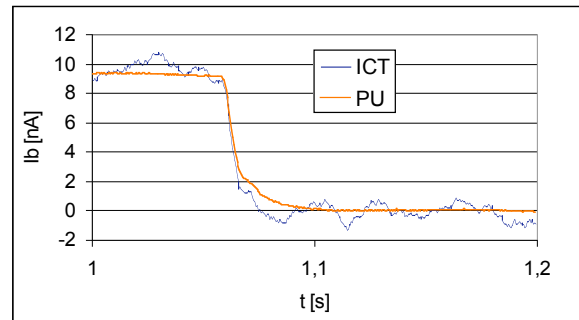

Figure 10: Current measurement made with ICT and PU. CD_3CND^+ ion beam current after acceleration with 16 averages, rf off after 1.06 s (BW=20 Hz).

We have calibrated and tested the linearity of the ICT and the related integrator over a current range of 1 nA-10 μA @363 kHz. The Agilent 332550A Function/Arbitrary Waveform Generator 2mV_p output voltage pulses with 25% duty cycle that were converted to $40 \mu\text{A}_p$ current pulses using 0.1% 50Ω resistor. A precision attenuator was used to cover the 10 μA to 1nA current range to be tested.

DATA ACQUISITION AND SOFTWARE

The measurements are controlled from a PC using LabVIEW 7. The input signals are sent to a National Instruments data acquisition card and then transferred to the PC. A LabVIEW program collects data, averages, subtracts background, saves data to file, and multiplies with the suitable transformer scale factor. The program also checks the incoming data such that good measurements are not corrupted.

REFERENCES

- [1] Bergoz, J., Beam Charge Monitor, Continuous Averaging User's Manual, Julien Bergoz.
- [2] A. Paal, A. Simonsson, A. Källberg, J. Dietrich and I. Mohos, Method and Instrumentation for Measurement of Low Ion Beam Currents at CRYRING, EPAC'04, Lucerne, July 2004, p. 2745.
- [3] J. Biri *et al.*, Beam Position Monitor Electronics at the Cooler Synchrotron COSY Juelich, 8th Real-Time Computer Applications in Nuclear, Particle and Plasma Physics (RT 93), Vancouver, British Columbia, Canada, 8-11 Jun 1993.