

# ACCT

## AC Current Transformer

Rev. 6.3



[www.bergoz.com](http://www.bergoz.com)

**bergoz**<sup>™</sup>  
INSTRUMENTATION

More than 40 years of experience recognized in the world of particle accelerators

## Record of updates

Version	Date	Updates performed
2.1	05/2008	p.3 - General Description: Parts numbers Reference to new High-Resolution and Wideband versions Output polarity: examples p.7 - Specifications High-Resolution specifications Wideband version specifications
3.1	01/2017	New release of the manual Reference to new specifications
4.0	03/2018	Review of the full manual. Obsoletes all former releases
5.0	06/2019	ACCT-E-RM-3R description and specifications added Option -3M added
5.1	06/2019	Modification of the cover page and creation of the distributors' page
5.2	01/2020	p.8 - Correction of one formula in "Operating Principle" chapter
5.3	02/2021	Removal of the In-Air ACCT dimensions with MSH option (no more available) Update of the drawing in the "INSTALLATION OVER A VACUUM CHAMBER" chapter
5.4	04/2021	Modification of the calibration winding option and ACCT-E-RM-3R to add systematically calibration winding on sensor when chosen
6.0	07/2024	Manual layout update
6.1	12/2024	50R option added in the ACCT electronics list of options
6.2	03/2026	Ratio accuracy correction
6.3	04/2026	Update with ACCT-E-RM-3R 220.3 Rev-C specifications ACCT-E-3R-RC (Range Controller) description

**DISTRIBUTORS**

**U.S.A.**

**GMW Associates**

GMW Associates  
[www.gmw.com](http://www.gmw.com)  
[sales@gmw.com](mailto:sales@gmw.com)

**Japan**

**HR HAYASHI-REPIC**

Hayashi-Repic Co., Ltd.  
[www.h-repic.co.jp](http://www.h-repic.co.jp)  
[sales@h-repic.co.jp](mailto:sales@h-repic.co.jp)

**India**

**GEEBEE**  
INTERNATIONAL

GEEBEE International  
[www.geebinternational.com](http://www.geebinternational.com)  
[info@geebinternational.com](mailto:info@geebinternational.com)

**China**

**CONVe-YI** 北京科维泰信

Beijing Conveyi Limited  
[www.conveyi.com](http://www.conveyi.com)  
[sales@conveyi.com](mailto:sales@conveyi.com)

**South Korea**

  
**SEYOUNG**

Seyoung Co., Ltd  
[www.seyoungsys.com](http://www.seyoungsys.com)  
[apark@seyoungsys.com](mailto:apark@seyoungsys.com)

---



**TABLE OF CONTENTS**

INITIAL INSPECTION ..... 2

WARRANTY ..... 2

ASSISTANCE ..... 2

SERVICE PROCEDURE ..... 2

RETURN PROCEDURE ..... 3

SAFETY INSTRUCTIONS..... 3

GENERAL DESCRIPTION ..... 4

ACCT ADVANTAGES COMPARED TO OTHER CTs..... 5

    In-flange models ..... 6

    In-air models..... 7

    ACCT electronics ..... 8

    Accessories..... 9

OPERATING PRINCIPLE..... 10

    Hereward transformer principle (1960)..... 11

ELECTRICAL CONNECTIONS ..... 12

    Connectors on the ACCT sensor ..... 12

    Connectors on ACCT-E-RM ..... 12

    Connectors on ACCT-E-RM-3R..... 13

OUTPUT SIGNAL POLARITY..... 16

COAXIAL OUTPUT CABLE SELECTION ..... 16

SPECIFICATIONS ..... 17

MECHANICAL DIMENSIONS AND DRAWINGS ..... 19

    In-flange models ..... 19

    In-air models..... 20

    Drawings..... 20

INSTALLATION..... 21

    In-flange models ..... 21

    In-air models..... 21

    Common mode filters..... 21

INSTALLATION OVER A VACUUM CHAMBER ..... 22

    Wall current break or “gap” ..... 22

    Thermal protection of the In-air ACCT ..... 22

    Keeping high harmonics of the beam out of the In-air ACCT cavity ..... 23

ACCT-S SENSOR RADIATION RESISTANCE..... 24

    Organic and radiation-sensitive materials used in the "Standard" sensor:..... 24

    Organic and radiation-sensitive materials used in the "Rad-Hard" sensor: ..... 24

## **INITIAL INSPECTION**

It is recommended that the shipment be inspected immediately upon delivery. If it is damaged in any way, contact Bergoz Instrumentation or your local distributor. The content of the shipment should be compared to the items listed on the invoice. Any discrepancy should be notified to Bergoz Instrumentation or its local distributor immediately. Unless promptly notified, Bergoz Instrumentation will not be responsible for such discrepancies.

## **WARRANTY**

Bergoz Instrumentation warrants its beam current monitors to operate within specifications under normal use for a period of 12 months from the date of shipment. Spares, repairs and replacement parts are warranted for 90 days. In exercising this warranty, Bergoz Instrumentation will repair, or at its option, replace any product returned to Bergoz Instrumentation or its local distributor within the warranty period, provided that the warrantor's examination discloses that the product is defective due to workmanship or materials and that the defect has not been caused by misuse, disassembly, neglect, use of faulty part, accident or abnormal conditions, repair made by the customer, or operations. Damages caused by ionizing radiations are specifically excluded from the warranty. Bergoz Instrumentation and its local distributors shall not be responsible for any consequential, incidental or special damages.

## **ASSISTANCE**

Assistance in installation, use or calibration of Bergoz Instrumentation beam current monitors is available from Bergoz Instrumentation, 01630 Saint Genis Pouilly, France. It is recommended to send a detailed description of the problem by email to [info@bergoz.com](mailto:info@bergoz.com).

## **SERVICE PROCEDURE**

Products requiring maintenance should be returned to Bergoz Instrumentation or its local distributor: The purchaser/customer must ask for a RMA (Return Material Authorization) number to Bergoz Instrumentation or its local distributor before return of goods. Bergoz Instrumentation will repair or replace any product under warranty at no charge.

For products in need of repair after the warranty period, Bergoz Instrumentation will assess the technical issue and send a quote to the purchaser/customer. The purchaser/customer must provide a purchase order before repairs can be initiated. Bergoz Instrumentation can issue fixed price quotations for most repairs.

## **RETURN PROCEDURE**

All products returned for repair should include a detailed description of the defect or failure as well as name, phone number and email of a contact person to allow further inquiry. Contact Bergoz Instrumentation or your local distributor to determine where to return the product. Returns must be notified by email prior to shipment.

The shipment of a product under warranty or out of warranty back to the factory is paid by the user/customer, including the customs fees. The return of this repaired product under warranty back to the customer is paid by Bergoz Instrumentation.

Return of product out of warranty should be made prepaid or will be invoiced. Bergoz Instrumentation will not accept freight-collect shipments. Shipments should be made via UPS, FedEx or DHL. Within Europe, the transportation services offered by the national Post Offices can be used. The delivery charges or customs clearance charges arising from the use of other carriers will be charged to the customer.

## **SAFETY INSTRUCTIONS**

The Toroid sensor contains materials such as cobalt and iron. Those materials may become radioactive when exposed to high energy particle beams. Follow applicable radiation-safety procedures when the Toroid sensor must be handled.

## GENERAL DESCRIPTION

The ACCT is specifically designed to measure average currents of long, continuous particle beam pulses or macropulses, i.e. rapid successions of many short particle beam pulses. It has an exceptionally low droop of <2%/ms. Most sensitive ACCTs have a full-scale range of 1 mA and less than 0.5  $\mu$ Arms noise.

The ACCT consists of a passive current transformer coupled to an external feedback electronics.

ACCT set includes:

- AC Current Transformer
- ACCT-E-RM-xxxmA or ACCT-E-RM-3R-xxxmA/yyymA/zzzmA external electronics box, where xxxmA/yyymA/zzzmA are the full scale primary current ranges. Electronics box can be mounted on a standard 35 mm DIN rail.
- ACCT sensor to ACCT-E electronics interconnect cable. Maximum cable length without degradation of the ACCT specifications is 20 meters:
  - ACCT-C-XX is a standard RG108 twinax cable with PVC jacket; "xx" is the cable length in meters.
  - or
  - ACCT-RHC-XX is a radiation-tolerant twinax cable with Siltem jacket (R.I. >7).
- Power supply unit mounted on a standard 35 mm DIN rail.

Note: ACCT is delivered without coaxial output cable.

The ACCT-E output voltage is highly linear. It features < 2uA rms noise and excellent dynamic response. This makes it an ideal instrument to measure long pulses or pulse trains.

ACCT sensor is available in two packaging styles: In-flange models or In-air models.



In-flange ACCT with ACCT-E-RM and power supply

## ACCT ADVANTAGES COMPARED TO OTHER CTs

The ACCT can measure weak low-frequency AC currents with high resolution and an accuracy <1%. Other current transformers cannot do this for the following reasons:

- A passive CT capable of detecting, for example, 50-60 Hz signals with less than 1% error must have a -3dB lower cutoff frequency below a few Hertz. This imposes a large number of turns, typically 500 turns. Therefore, the sensitivity is in the order of 0.1 V/A in a high impedance load.
- If a 1 mA current is measured with such a CT, its output voltage is a mere 100  $\mu$ V, whereas an ACCT with 1 mA full scale range would output 10 V. To achieve the same noise as this ACCT (2  $\mu$ Arms), the CT read-out system, e.g. oscilloscope or ADC, would need a resolution of 0.2  $\mu$ Vrms. Such an extreme resolution is impossible to achieve, especially when considering the ACCT bandwidth of 1 MHz.

### In-flange models

In-flange models are current transformers whose cores are embedded in a pair of vacuum flanges. Flanges are Conflat with usual inner diameters.

These current transformers are UHV compatible at least to 1e-9 mbar. Soap or alcohol cleaning before installation is however recommended. To reach pressure down to 1e-11 mbar, adequate pumping and prior cleaning, e.g. plasma, are required.

Current transformer temperature should never exceed 100°C (212°F) at any time during bake out or operation unless the current transformer is made from a selection of higher temperature alloys and materials:

- Option BK150C allows bake out at 150°C (300°F)
- Option BK185C allows bake out at 185°C (365°F)
- Option BK200C allows bake out at 200°C (392°F)

Current transformer wall current break (“gap”) is a ceramic ring (Al<sub>2</sub>O<sub>3</sub> 99.7%) brazed onto two Kovar transition sleeves.

Standard models are made from AISI 304 steel, AISI 316LN is available on option.

In-flange ACCT part numbers follow below syntax:

In-flange ACCT	
-CFx”-	x” is the CF flanges OD [inch]
-xx.x-	xx.x is the sensor ID [mm]
-xx-	xx is the sensor axial length [mm] <i>Axial length of standard sensors is 40 mm</i>
-UHV-	UHV: Sensor UHV compatible with brazed ceramic wall current breaks <i>As delivered down to 1e-9 mbar</i> <i>After adequate cleaning down to 1e-11 mbar</i>
Example: ACCT-CF6”-60.4-40-UHV	
Available options for In-flange ACCT	
-LN	Low Noise option
-ARBxx-	In-flange ACCT sensor with special arbitrary aperture, 50mm axial length
-316LN-	In-flange ACCT sensor in AISI316LN instead of 304
-BK150C-	In-flange ACCT sensor bakeable at 150°C (300°F)
-BK185C-	In-flange ACCT sensor bakeable at 185°C (365°F)
-BK200C-	In-flange ACCT sensor bakeable at 200°C (365°F)
-SH2L-	2-layer embedded shield option
-SH4L-	4-layer embedded shield option
-H	Radiation-tolerant sensor option, all components R.I.>6
-CAW1_50	One turn calibration winding option, loaded 50Ω (0.25W), insulated, SMA connector

### In-air models

In-air models are current transformers whose cores are potted in a toroidal copper casing. In-air ACCTs are typically installed over a vacuum chamber whose wall current flow is interrupted by a user-installed break (“gap”) protected from stress by bellows. The wall current is diverted by a user-installed wall current bypass. A user-installed shield prevents RF fields radiating out of the gap.

In-air ACCT should not be heated above 100°C (212°F) at any time.

In-air ACCT should not be placed in vacuum, they might burst.

Specially degassed In-air ACCT with option -VAC can be placed in low vacuum (1e-4 mbar).

In-air ACCT part numbers follow below syntax:

In-air ACCT	
-S-	
-xxx-	xxx is the sensor ID [mm]
Example: ACCT-S-055	
Options for In-air ACCT	
-LN	Low Noise option
-SH2L-	2-layer embedded shield option
-SH4L-	4-layer embedded shield option
-H	Radiation-tolerant sensor option, all components R.I.>6
-CAW1_50	One turn calibration winding option, loaded 50Ω (0.25W), insulated, SMA connector
-VAC	Sensor degassing option, for vacuum > 10 <sup>-4</sup> mbar



In-Air ACCT

### ACCT electronics

ACCT electronics have to be connected to the ACCT sensor with a RG108 twinax cable fitted with BNO connectors (also called twinax or twin BNC) and common-mode filters.



BNO connector

ACCT electronics is available in two versions:

a) ACCT-E-RM with a single full-scale range

ACCT-E-RM output signal is a high-impedance bipolar voltage with  $\pm 10$  V full scale range.

Output voltage is proportional to the beam current passing the ACCT sensor aperture.

Example: ACCT-E-RM-10mA has -10 V output voltage when a current of -10 mA is passing the ACCT sensor aperture.

b) ACCT-E-RM-3R with 3 selectable full-scale ranges. It has the following additional features:

- 3 selectable full-scale ranges
- 3 outputs: High impedance, 50  $\Omega$  and Differential
- Integrated calibrated current source (applicable when ACCT sensor is equipped with option -CAW1)
- TTL controllable
- 1-turn calibration winding with BNO connector mounted on the sensor

ACCT-E-RM and ACCT-E-RM-3R are both powered by +15 V and -15 V supplied to the screw terminal.

It is recommended to use the ACCT-PS-1515 power supply provided by Bergoz Instrumentation. Noise specifications are only guaranteed when this power supply is used.

ACCT-E-RM, ACCT-E-RM-3R and ACCT-PS-1515 can be mounted on a standard 35 mm DIN rail.

ACCT electronics part numbers below syntax:

ACCT electronics	
ACCT-E-RM-xxxmA	Full scale range of xxxmA.
ACCT-E-RM-3R-xxxmA/yyymA/zzzmA	Three selectable full-scale ranges, xxx mA, yyy mA and zzz mA.
Example: ACCT-E-RM-20mA or ACCT-E-RM-3R-1mA/10mA/100mA	
Available options for ACCT electronics	
-3M	Bandwidth extended to 3 MHz Maximum cable length is then limited to 7m
-50R	ACCT output readout to be read into 50ohms

## Accessories

### ACCT-E-3R-RC – Range Controller for ACCT-E-RM-3R

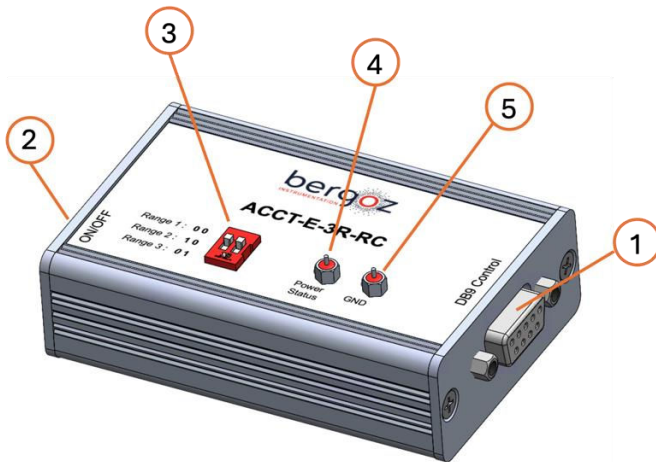

The ACCT-E-3R-RC is a battery-operated device designed to control the ACCT-E-RM-3R ranges.

Its Sub-D9 connector (1) must be connected to that of the ACCT-E-RM-3R using the flat ribbon cable supplied with the device.

An On/Off switch (2) located on the side of the device allows its activation.

Two DIP switches (3) allow to set the desired range; TTL signal are then injected on Pin 1 and 2 of the Sub-D9 connector (1) accordingly.

The TTL signals are referenced to the internal ground, available on Pin 6 of the Sub-D9 connector (1), and on the through capacitor (5).

The power status provided by the ACCT-E-RM-3R is available on the through capacitor (4), referenced to the internal ground (5).

The device can operate solely with its internal battery.

The +5Vdc battery charger supplied with the device can remain plugged in during operation.

## OPERATING PRINCIPLE

The ACCT measures low frequency currents in the range 3 Hz to 1 MHz. It is not simply a transformer with an amplified output, because such a combination remains unable to measure low currents at low frequency.

The lower frequency cutoff (-3 dB) of a transformer is given by:

$$f_L = \frac{R}{2\pi \cdot L}$$

Where:

- $L$  is the core winding inductance
- $R$  is the winding load

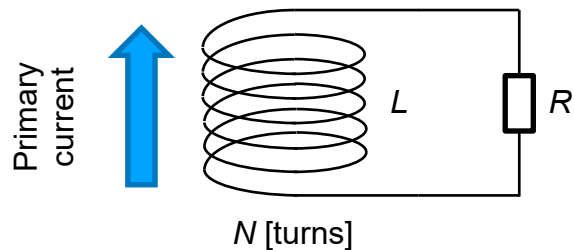

To obtain a low value for  $f_L$ , either  $R$  must be decreased, or  $L$  must be increased. The inductance  $L$  cannot be increased beyond a certain value because physics laws and economics prevent it. The inductance is given by:

$$L = \mu_r \mu_0 \frac{N^2 A}{l}$$

where  $\mu_r$  is the core alloy relative permeability  
 $A$  is the core magnetic cross section  
 $l$  is the magnetic path length (core average circumference)  
 $N$  is the number of winding turns

$\mu_r$  is characteristic for the magnetic alloy and annealing process. The ACCT uses cobalt-based alloys specifically annealed for this application. High temperature bake-out models use iron-based nanocrystalline alloys. Both alloys feature very high permeability.

$A$  is limited by the size of the sensor and the economics (high performance alloys are expensive).

$l$  is imposed by the sensor sized.

$N$  is the only parameter which is allowed to vary significantly.

When  $N$  is increased,  $L$  increases with  $N^2$ , which is very favorable for the low frequency response. But at the same time, the sensitivity decreases by  $N$ . Hence, the signal level decreases and becomes too close to the noise floor to make meaningful measurements.

This is why the ACCT has a moderate number of turns ( $\approx 100$ , depending on the model) and instead of increasing  $L$  for low frequency response is designed with a very low  $R$  load value.

Already Hereward<sup>1</sup> proposed in 1960 an active transformer with very low impedance load.

<sup>1</sup> J.B. Sharp, The induction type beam monitor for the PS: Hereward transformer, CERN MPS/Int. CO 62-15 (1962)

### Hereward transformer principle (1960)

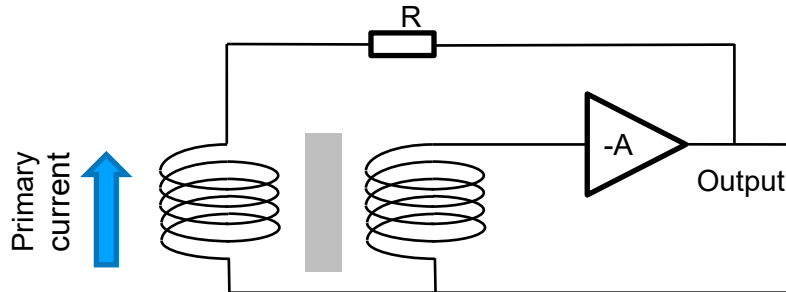

To provide the AC response of the first DCCT ever built, K. Unser<sup>2</sup> in 1969 improved and simplified Hereward's circuit diagram:

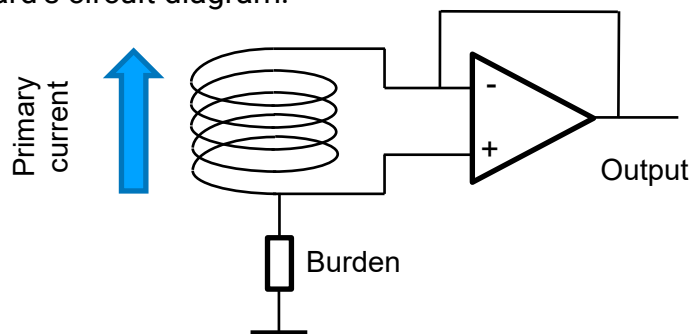

In this circuit, the impedance seen by the winding is close to  $0 \Omega$ , because the operational amplifier maintains at all times the voltage difference between its inputs very close to zero. The ACCT implements this principle.

The ACCT incorporates another innovative technique to null the operational amplifier's offset. As a result, the ACCT offset voltage remains very close to zero when no primary current flows through the sensor.

<sup>2</sup> K. Unser, IEEE Trans. Nucl. Sci., NS-16, (1969) 934

## ELECTRICAL CONNECTIONS

### Connectors on the ACCT sensor

#### *Output*

BNO female connector, grounded to sensor body.

### Connectors on ACCT-E-RM



#### *Input*

BNO female connector, to be connected to the ACCT sensor output BNO with a twinax RG108 cable fitted with BNO connectors (also called twinax or twin BNC) and common-mode filters.

#### *Output*

BNC connector, to be read by a high impedance input.  
 -10 V to +10 V proportional to the selected range full scale.  
 Maximum output current drive: 32 mA source or sink.

#### *Power Supply*

ACCT-E-RM is powered with +15 V and -15 V, 15 W.

It is recommended to use the ACCT-PS-1515 power supply provided by Bergoz Instrumentation. This power supply guarantees the ACCT-E-RM output noise specifications.

It is recommended to use twisted wires to connect the power supply. Passing the wires through a common-mode choke is advisable.

## Connectors on ACCT-E-RM-3R

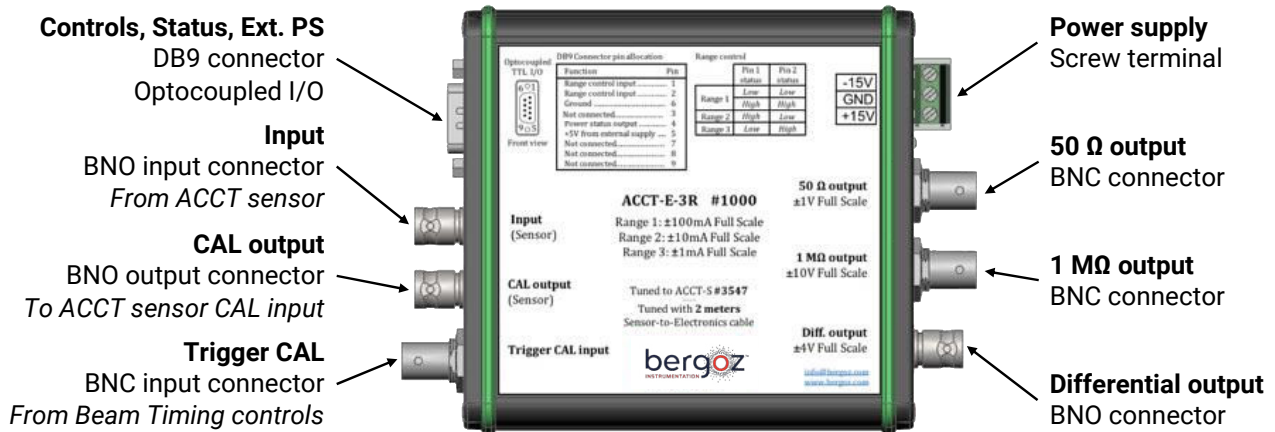

### Input

BNO female connector, to be connected to the ACCT sensor output BNO with a twinax RG108 cable fitted with BNO connectors (also called twinax or twin BNC) and common-mode filters.

### CAL output

BNO female connector, to be connected to the ACCT sensor calibration winding output BNO with a twinax RG108 cable fitted with BNO connectors (also called twinax or twin BNC) and common-mode filters.

The calibrated current pulse is generated by the ACCT-E-RM-3R electronics and injected into the sensor calibration winding via the sensor CAL input connector. Its amplitude is adjusted to 50% of the full scale of the selected range.

For example, when the range selected is 10 mA, the amplitude of the calibrated current pulse is 5 mA.

The maximum calibrated current is 250 mA. For ranges beyond 500 mA, the amplitude of the calibration current pulse remains 250 mA.

The calibrated current pulse length is defined by the Trigger CAL signal length.

### Trigger CAL input

Trigger signal controlling the calibrated current pulse.

BNC female connector, to be connected to a trigger signal generator with TTL levels. The calibrated current pulse length is equal to the trigger pulse length.

### Power Supply

The ACCT-E-RM-3R is powered with +15 V and -15 V, 15 W.

It is recommended to use the ACCT-PS-1515 power supply provided by Bergoz Instrumentation. This power supply guarantees the ACCT-E-RM-3R output noise specifications.

It is recommended to use twisted wires to connect the power supply. Passing the wires through a common-mode choke is advisable.

*50 Ω output*

BNC connector, 50 Ω output impedance.

To be read by a 50 Ω impedance input.

-1 V to +1 V proportional to the selected range full scale.

Maximum output current drive: 32 mA source or sink.

*1 MΩ output*

BNC connector, 50 Ω output impedance.

To be read by a high impedance input.

-10 V to +10 V proportional to the selected range full scale.

Maximum output current drive: 32 mA source or sink.

*Differential output*

BNO connector, 50 Ω single-ended output impedance (100 Ω differential output impedance).

-4 V to +4 V proportional to the selected range full scale, when read in high impedance.

-2 V to +2 V proportional to the selected range full scale, when read in 50 Ω impedance.

Maximum output current drive: 40 mA source or sink.

*DB9 Connector pin allocation*

<i>Function</i>	<i>Pin</i>
Range Control input .....	1
Range Control input .....	2
Ground .....	6
Not connected.....	3
Power Status output .....	4
+5V from external power supply .....	5
Not connected.....	7
Not connected.....	8
Not connected.....	9

DB9 connector input and output signals are TTL levels.

Range Control input (pin 1 & 2)

<i>Pin 1 status</i>	<i>Pin 2 status</i>	<i>Range</i>
Low	Low	Range 1
High	High	Range 1
High	Low	Range 2
Low	High	Range 3

**Power Status output (pin 4)**

High when ACCT-E-3R is powered.

Low when ACCT-E-3R is not powered.

Since this output is optocoupled, +5 V must be provided on pin 5 of the DB9 connector to activate this functionality.

**Ground (input, pin 6)**

Reference of the TTL signals and +5V EXT (pin 5).

**+5V from external power supply (input, pin 5)**

+5V (referenced to Ground, pin 6) must be applied to activate the Power Status functionality.

## **OUTPUT SIGNAL POLARITY**

The ACCT is bipolar. That means it can measure positive or negative currents passing the sensor aperture in either direction.

An arrow is printed on the outer surface of the ACCT sensor to indicate the recommended direction of installation.

Positive charges e.g. protons, crossing the sensor aperture in the direction of the arrow give a positive output.

Negative charges e.g. electrons, crossing the sensor aperture in the direction of the arrow give a negative output.

## **COAXIAL OUTPUT CABLE SELECTION**

Unless specially requested, no output coaxial cable is supplied with the ACCT.

The ACCT signal is a low frequency signal up to 3 MHz. Most coaxial cables can be used to connect ACCT-E output and, for example, oscilloscope input. However, for longer distances and in high EMI environments, it is advisable to use high quality, low loss cables.

Additionally, it is recommended to pass the coaxial cable through common-mode filters of two types:

- MnZn ferrite cores, tubes or beads for high-frequency noise rejection
- Soft-annealed nano-crystalline cores for low-frequency noise rejection

## SPECIFICATIONS

Full scale range	Any value from $\pm 1\text{mA}$ to $\pm 2\text{A}$ , factory preset range.
Ratio accuracy	$<1\%$
Lower cutoff (-3dB)	$<3\text{Hz}$
Droop	$<2\%/ms$
Upper cutoff (-3dB)	1MHz
Risetime	350ns (10% - 90%)
Noise at 10mA F.S.	$\approx 1.5\mu\text{Arms}$
Noise at 100mA F.S.	$<5\mu\text{Arms}$

### Single range electronics

1M $\Omega$ output full scale	-10V ... +10V in high impedance
50 $\Omega$ output full scale (50R option)	-1V ... +1V in 50 $\Omega$
Output offset	0.5mV max.
Output current limit	50 $\Omega$ output (50R option): 32mA max. 1M $\Omega$ output: 32mA max
Connectors	Electronics input: BNO (twinax or twin BNC) Electronics output: BNC

### 3-range electronics

1M $\Omega$ output full scale	-10V ... +10V in high impedance
50 $\Omega$ output full scale	-1V ... +1V in 50 $\Omega$
Differential output full scale	-4V ... +4V in high impedance
Output offset	50 $\Omega$ output: $<0.5\text{mV}$ 1M $\Omega$ output: $<0.5\text{mV}$ Differential output: $<1\text{mV}$
Output current limit	50 $\Omega$ output: 32mA max. 1M $\Omega$ output: 32mA max. Differential output: 40mA max.
CAL output	Output pulse amplitude equal to 50% of the full scale of the selected range Output pulse length defined by the Trigger CAL input signal length (TTL)
Connectors	Signal input: BNO (twinax or twin BNC) CAL output: BNO (twinax or twin BNC) Trigger CAL input: BNC 50 $\Omega$ output: BNC 1M $\Omega$ output: BNC Differential output: BNO (twinax or twin BNC)

**Others**

Power supply	+15Vdc and -15Vdc, 100mA each
Power supply unit	ACCT-PS-1515 recommended Mains voltage 95-125Vac / 215-245Vac
Calibration winding	1-turn calibration winding, loaded 50Ω (0.25W); insulated
Connectors	Sensor winding: BNO (twinax or twin BNC) Sensor CAL winding: SMA; BNO with ACCT-E-RM-3R
Sensor cable	twinax RG108 cable Up to 20 meters Above 20 meters overshoot may appear and rise time may increase
CAL winding cable	twinax RG108 cable
Destructive levels	DC current: unlimited Spikes >100 mC AC current >20 Arms
Sensor saturation	External DC magnetic field: Transverse to sensor axis: 2mT max Collinear with sensor axis: 10mT max Can be exceeded with optional embedded shielding, options SH2L/SH4L
Temperature drift	Sensor: Typ. -40 ppm/°C Electronics: <ul style="list-style-type: none"> <li>• 1MΩ output: Typ. +150 ppm/°C</li> <li>• 50Ω output: Typ. +50 ppm/°C</li> </ul>

## MECHANICAL DIMENSIONS AND DRAWINGS

### In-flange models

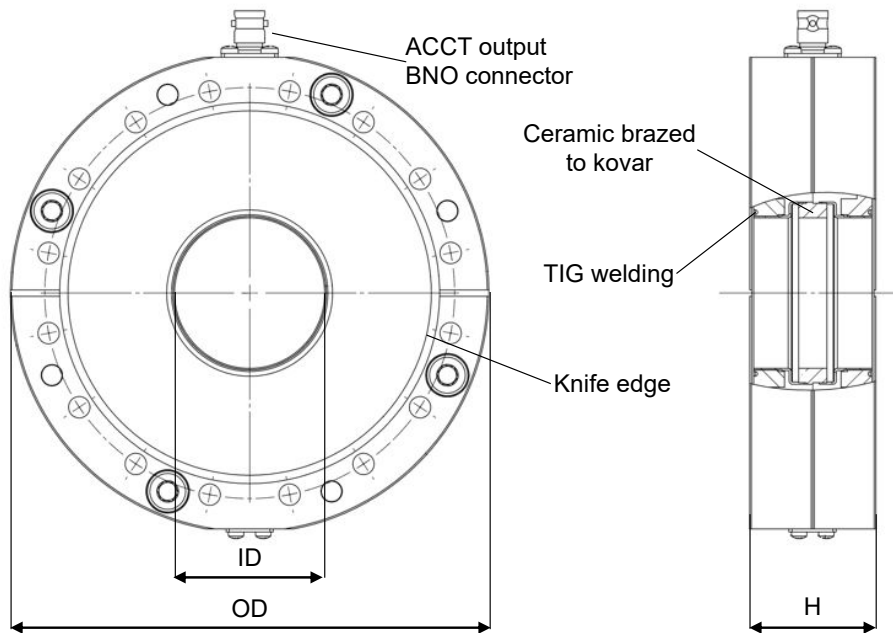

In-flange ACCT sensor order code	ACCT OD (inch)	Pipe OD (inch)	Mating flange	ACCT ID (mm)	ACCT H (mm)
ACCT-CF3"3/8-22.2-40-UHV	3.375"	1"	DN/NW50CF	22.2	40
ACCT-CF4"1/2-34.9-40-UHV	4.5"	1.5"	DN/NW63CF	34.9	40
ACCT-CF4"1/2-38.0-40-UHV	4.5"	40 mm	DN/NW63CF	38.0	40
ACCT-CF6"-47.7-40-UHV	6"	2"	DN/NW100CF	47.7	40
ACCT-CF6"-60.4-40-UHV	6"	2.5"	DN/NW100CF	60.4	40
ACCT-CF6"3/4-96.0-40-UHV or ACCT-CF8"-96.0-40-UHV	6.75" 8"	4"	DN/NW130CF DN160/NW150CF	96.0	40
ACCT-CF10"-147.6-40-UHV	10"	6"	DN/NW200CF	147.6	40
ACCT-CF12"-198.4-40-UHV	12"	8"	DN/NW250CF	198.4	40

\* When -LN option is required, please ask Bergoz Instrumentation for feasible standard dimensions.

**In-air models**

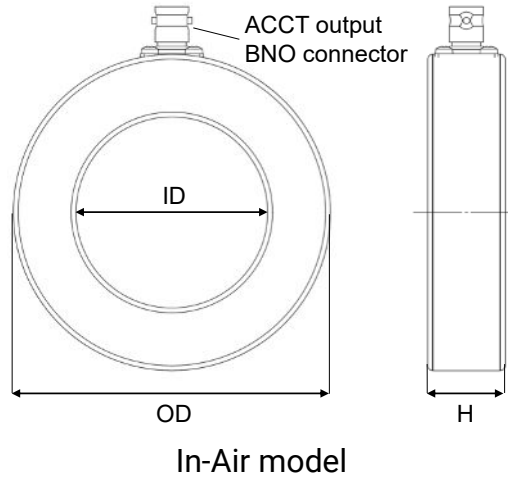

In-air ACCT sensor order code	ID (mm)	OD (mm)	H (mm)	Mass (g)
Unshielded models				
ACCT-S-016	16	42	22	60
ACCT-S-028	28	64	22	115
ACCT-S-055	55	91	22	175
ACCT-S-082	82	118	22	250
ACCT-S-122	122	156	22	320
ACCT-S-178	178	226	22	700

\* When -LN option is required, please ask Bergoz Instrumentation for feasible standard dimensions.

**Drawings**

Drawings in .pdf can be found on our website:  
[www.bergoz.com](http://www.bergoz.com) >> Products >> ACCT >> Downloads >> Technical drawings

Dimensions missing on the website can be obtained by contacting [info@bergoz.com](mailto:info@bergoz.com)

## INSTALLATION

### In-flange models

In-flange ACCT mechanical parts are in direct electrical contact with the vacuum chamber. Its output connector body and, hence, the coaxial cable shield are also in direct electrical contact with the vacuum chamber.

It is therefore important to equip every segment of the coaxial cable with common mode filters to mitigate ground loops. A cable segment is any section of cable between two grounded connectors or bulkheads, for example, through a grounded patch panel.

In-flange ACCT bolts must be tightened at the recommended torque according to the flange type, but not beyond.

### In-air models

In-air ACCT must be installed over the vacuum chamber, not too far away from the wall current gap. It is recommended to install bellows to avoid stress on the gap, wall current bypass and RF overall shield.

The output connector body is in direct electrical contact with the In-air ACCT copper shell. Therefore, to prevent ground loops, it is recommended that the In-air ACCT shell is electrically isolated from the vacuum chamber.

### Common mode filters

To improve EMI rejection common mode filters should be installed at both ends of each cable segment. Each filter shall comprise a MnZn ferrite core for high frequency >500 MHz rejection, and an iron-based nanocrystalline core with soft B-H loop for low frequency rejection.

## INSTALLATION OVER A VACUUM CHAMBER

The installation of an In-air ACCT on the outside of a vacuum chamber requires some precautions.

- a) The electrical conductivity of the vacuum chamber must be interrupted in the vicinity of the ACCT, otherwise beam and beam-induced wall current will flow through the ACCT aperture and cancel each other. This vacuum chamber electrical break should be designed to be high impedance over the entire ACCT bandwidth, but low impedance at higher frequencies. The higher harmonics of the beam induced fields should be prevented from escaping the vacuum chamber, because:
  - a. they are not "seen" by the ACCT therefore unnecessary
  - b. they heat the ACCT and any other conductive materials inside wall current bypass and RF shield
  - c. they cause various ringing modes inside wall current bypass and RF shield.
- b) Wall current DC and very low frequency components must be diverted around the ACCT through a low impedance path.
- c) A fully enclosing RF shield must be installed over wall current bypass, ACCT and vacuum chamber electrical break to avoid emission of RF radiation.
- d) The enclosing shield forms a cavity. cavity ringing at any of the beam harmonics must be avoided.
- e) The ACCT must be protected from being heated beyond 100°C (212°F) during vacuum chamber bake-out.

### Wall current break or "gap"

When installing an In-air ACCT over a vacuum chamber, an electrical break or "gap" must be installed in order to stop the wall current induced by the beam.

If vacuum pressure is  $1e-7$  mbar or above, a polymer gasket O-ring can be used between two flanges to assure the desired electrical isolation.

For vacuum pressures below  $1e-7$  mbar, a ceramic ring brazed to the vacuum chamber is indicated.

### Thermal protection of the In-air ACCT

The ACCT must not be heated beyond 100°C (212°F). If the vacuum chamber requires bake out, a thermal shield must be installed between the vacuum chamber (or the heating sleeves) and the ACCT.

The thermal shield can be a simple copper cylinder cooled by water circulating in a copper tube brazed onto the cylinder.

The water circuit must not pass through the ACCT aperture. It must enter and leave on the same side of the ACCT, otherwise it may create an electrical short around the ACCT toroid.

---

### Keeping high harmonics of the beam out of the In-air ACCT cavity

Wall current break, wall current bypass and RF shield form together a cavity. The ACCT sensor is placed inside this cavity.

The beam current flows through the vacuum chamber. Its electromagnetic fields induce a wall current in the conductive vacuum chamber walls. The flow of this wall current is interrupted by the wall current break. Depending on gap capacitance, high frequency components see a low impedance and continue to flow over the gap. DC and lower frequency components see a high impedance and are diverted over the wall current bypass. Depending on cavity geometry also some high frequency resonances may be present inside the cavity.

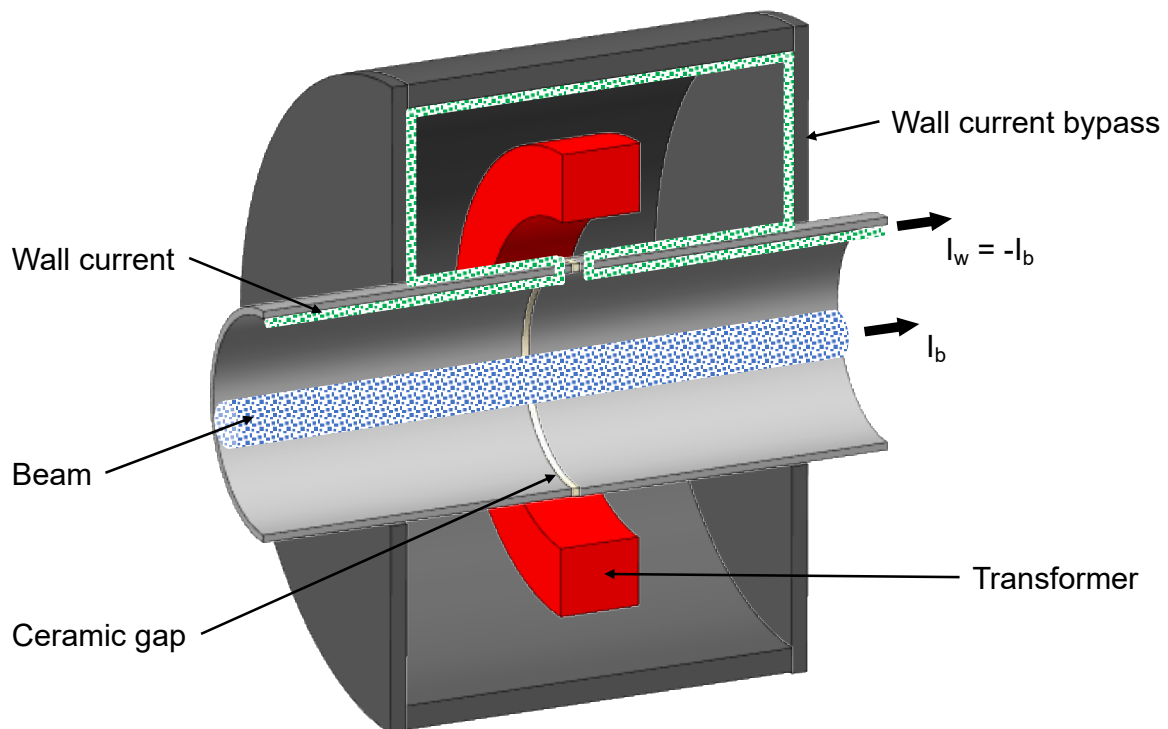

The transformer “sees” all currents passing through its aperture, i.e. beam current  $I_b$  and high frequency components of wall current  $I_w$ . Since these two currents cancel each other, only the beam current components whose corresponding wall current is diverted over the wall current bypass and the high frequency resonances are visible to the transformer. Only these currents induce a magnetic flux in its core.

By increasing the gap capacitance all unnecessary frequencies can be kept out the cavity. By reducing the size of the cavity high frequency resonances can be avoided.

Note that always the full charge of the beam current pulse is visible to the transformer, irrespective of the value of the gap capacitance.

## ACCT-S SENSOR RADIATION RESISTANCE

ACCT-S sensor contains material which may be damaged by ionizing radiations. They are listed hereafter:

### Organic and radiation-sensitive materials used in the "Standard" sensor:

The "Standard" sensor is supplied when the "Rad-Hard" option is not ordered.

Component		Material	Radiation resistance <sup>3</sup>
Wiring insulation		Polyvinyl chloride PVC	$2 \times 10^5$ Gy
		Fiber glass	$> 10^8$ Gy
		with rubber adhesive	$> 10^6$ Gy
		Silicon rubber tape SIR	$5 \times 10^5$ Gy
		Silicon rubber SIR	$2 \times 10^5$ Gy
Output connector	Twin BNC	ETFE "Tefzel"	$10^6$ Gy
Calibration connector	SMA	PTFE "Teflon"	$< 10^3$ Gy

### Organic and radiation-sensitive materials used in the "Rad-Hard" sensor:

The "Rad-Hard" sensor is supplied when the "Rad-Hard" option is ordered. The ordering code and model number are then terminated by -H.

Component		Material	Radiation resistance <sup>3</sup>
Wiring isolation		Polyether-ether-ketone PEEK	$6 \times 10^7$ Gy
		Fiber glass	$> 10^8$ Gy
		with rubber adhesive	$> 10^6$ Gy
Stress absorbent		Polyurethane foam PU	$5 \times 10^6$ Gy
		Polyurethane rubber PUR	$5 \times 10^6$ Gy
Output connector	Twin BNC	ETFE Tefzel	$10^6$ Gy
Calibration connector	SMA	Polyether-ether-ketone PEEK	$6 \times 10^7$ Gy

The above radiation resistance values are indicative only. They do not imply any guarantee of whatever nature of the manufacturer.

The manufacturer specifically declines any responsibility for any damage, direct or consequential, caused by ionizing radiations.

<sup>3</sup> Source: *Compilation of Radiation Damage Test Data*, H. Schönbacher et al.,  
 CERN 79-04: <http://cds.cern.ch/record/133188/files/CERN-HS-RP-038-YR-PART1.pdf?version=1>  
 CERN 79-08: <http://cds.cern.ch/record/141784/files/CERN-HS-RP-093.pdf?version=1>  
 CERN 82-10: <http://cds.cern.ch/record/141784/files/CERN-HS-RP-093.pdf?version=1>  
 CERN 89-12: <http://cds.cern.ch/record/205520/files/CERN-89-12.pdf?version=1>

More information and latest manuals revisions can be found on our website

[www.bergoz.com](http://www.bergoz.com)

If you have any questions, feel free to contact us by e-mail

[info@bergoz.com](mailto:info@bergoz.com)

