

MX-BPM

Multiplexed Beam Position Monitor

Rev. 3.0

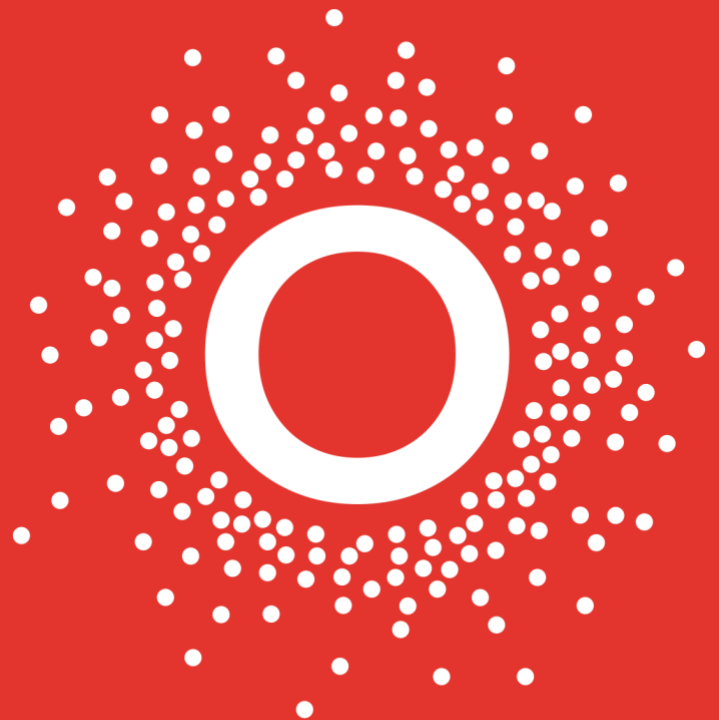

www.bergoz.com

bergoz[™]
INSTRUMENTATION

More than 40 years of experience recognized in the world of particle accelerators

Record of updates

Version	Date	Updates performed
2.0	01/2020	Review of the full manual. Obsoletes all previous versions
3.0	07/2024	Manual layout update

DISTRIBUTORS

U.S.A.

GMW Associates

GMW Associates
www.gmw.com
sales@gmw.com

Japan

HR HAYASHI-REPIC

Hayashi-Repic Co., Ltd.
www.h-repic.co.jp
sales@h-repic.co.jp

India

GEEBEE
INTERNATIONAL

GEEBEE International
www.geebeginternational.com
info@geebeginternational.com

China

CONVe-YI 北京科维泰信

Beijing Conveyi Limited
www.conveyi.com
sales@conveyi.com

South Korea

**SEYOUNG**

Seyoung Co., Ltd
www.seyoungsys.com
apark@seyoungsys.com

TABLE OF CONTENTS

INITIAL INSPECTION3

WARRANTY3

ASSISTANCE3

SERVICE PROCEDURE.....3

RETURN PROCEDURE4

SAFETY INSTRUCTIONS4

BEAM POSITION MONITOR SYSTEM5

QUICK CHECK.....6

 What if the display does not look as shown?.....8

 Getting familiar with the BPM8

ON-BOARD ATTENUATORS ADJUSTMENT9

 Introduction9

BUTTON SAMPLING.....9

EXTERNAL CLOCK10

ALGORITHM & POLARITY CONVENTION10

 45° buttons10

 Orthogonal buttons.....10

PRINCIPLE OF OPERATION.....11

BLOCK DIAGRAM11

PERFORMANCE.....12

 Sampling frequency.....12

 Output signal noise (resolution) vs. input signal strength.....12

 Position error (linearity) vs. input signal strength.....13

 Temperature drift.....14

CLOSED ORBIT OPERATING MODE15

X AND Y GAIN ADJUSTMENT16

 Conventions16

 BPM module gain adjustment.....16

LOCAL OSCILLATOR PROGRAMMING16

 Introduction16

 Changing the LO frequency17

SIGNALS18

 Button Inputs18

 Auxiliary fast signals18

Common external controls.....	18
Input and output signals.....	19
BPM CABLES LAYOUT, INSTALLATION	21
Cable layout	21
OPERATING CONSIDERATIONS.....	22
BPM aliasing of AM and FM modulations	22
Identifying and eliminating aliasing	22
CONNECTORS PINS ALLOCATION Rev. 4.0	24
BPM CHASSIS	25
Description.....	25
Chassis rear view.....	25
SPECIFICATIONS.....	26
BPM module	26
Power Supply module.....	26
BPM MODULE REAR CONNECTOR DIN41612M 24+8	27

INITIAL INSPECTION

It is recommended that the shipment be inspected immediately upon delivery. If it is damaged in any way, contact Bergoz Instrumentation or your local distributor. The content of the shipment should be compared to the items listed on the invoice. Any discrepancy should be notified to Bergoz Instrumentation or its local distributor immediately. Unless promptly notified, Bergoz Instrumentation will not be responsible for such discrepancies.

WARRANTY

Bergoz Instrumentation warrants its beam current monitors to operate within specifications under normal use for a period of 12 months from the date of shipment. Spares, repairs and replacement parts are warranted for 90 days. In exercising this warranty, Bergoz Instrumentation will repair, or at its option, replace any product returned to Bergoz Instrumentation or its local distributor within the warranty period, provided that the warrantor's examination discloses that the product is defective due to workmanship or materials and that the defect has not been caused by misuse, disassembly, neglect, use of faulty part, accident or abnormal conditions, repair made by the customer, or operations. Damages caused by ionizing radiations are specifically excluded from the warranty. Bergoz Instrumentation and its local distributors shall not be responsible for any consequential, incidental or special damages.

ASSISTANCE

Assistance in installation, use or calibration of Bergoz Instrumentation beam current monitors is available from Bergoz Instrumentation, 01630 Saint Genis Pouilly, France. It is recommended to send a detailed description of the problem by email to info@bergoz.com.

SERVICE PROCEDURE

Products requiring maintenance should be returned to Bergoz Instrumentation or its local distributor: The purchaser/customer must ask for a RMA (Return Material Authorization) number to Bergoz Instrumentation or its local distributor before return of goods. Bergoz Instrumentation will repair or replace any product under warranty at no charge.

For products in need of repair after the warranty period, Bergoz Instrumentation will assess the technical issue and send a quote to the purchaser/customer. The purchaser/customer must provide a purchase order before repairs can be initiated. Bergoz Instrumentation can issue fixed price quotations for most repairs.

RETURN PROCEDURE

All products returned for repair should include a detailed description of the defect or failure as well as name, phone number and email of a contact person to allow further inquiry. Contact Bergoz Instrumentation or your local distributor to determine where to return the product. Returns must be notified by email prior to shipment.

The shipment of a product under warranty or out of warranty back to the factory is paid by the user/customer, including the customs fees. The return of this repaired product under warranty back to the customer is paid by Bergoz Instrumentation.

Return of product out of warranty should be made prepaid or will be invoiced. Bergoz Instrumentation will not accept freight-collect shipments. Shipments should be made via UPS, FedEx or DHL. Within Europe, the transportation services offered by the national Post Offices can be used. The delivery charges or customs clearance charges arising from the use of other carriers will be charged to the customer.

SAFETY INSTRUCTIONS

This instrument is operated from the mains power supply. For safe operation, it must be grounded by way of the grounding conductor in the power cord. Use only the fuse specified. Do not remove cover panels while the instrument is powered. Do not operate the instrument without the cover panels properly installed.

Chassis originally shipped to U.S. or Canada feature AC mains power entry modules where the Phase is fused and the Neutral unfused, as is the rule.

Chassis to other destinations but U.S. and Canada feature AC mains power entry modules where both Phase and Neutral are fused.

When a chassis with unfused Neutral shall be used outside the U.S. and Canada, fuse configuration must be modified so that both Phase and Neutral will be fused:

The Power entry module must be opened, the Phase fuse must be removed, the fuse holder must be flipped; its reverse side presents two slots where two new fuses must be inserted, one in each slot. The fuses rating must be same as the Phase fuse that was removed.

BEAM POSITION MONITOR SYSTEM

The BPM system includes:

<i>Description</i>	<i>Order code</i>
BPM electronics module	BPM-XXX.XXMHz....
19" chassis with power supply	BPM-RFC/X, X = BPM stations number

If included, these options are mounted on the BPM electronics module.

Check that the voltage of the power supply corresponds to the mains voltage.

On the table-top kit: The voltage is indicated on the power supply module.

If it does not correspond, use a transformer or contact the manufacturer to get another power supply.

In the 19" chassis: The power supply is autoranging (98V...264V) and does not need any adjustment.

QUICK CHECK

You can check immediately that your BPM system is working. Use the following set-up:

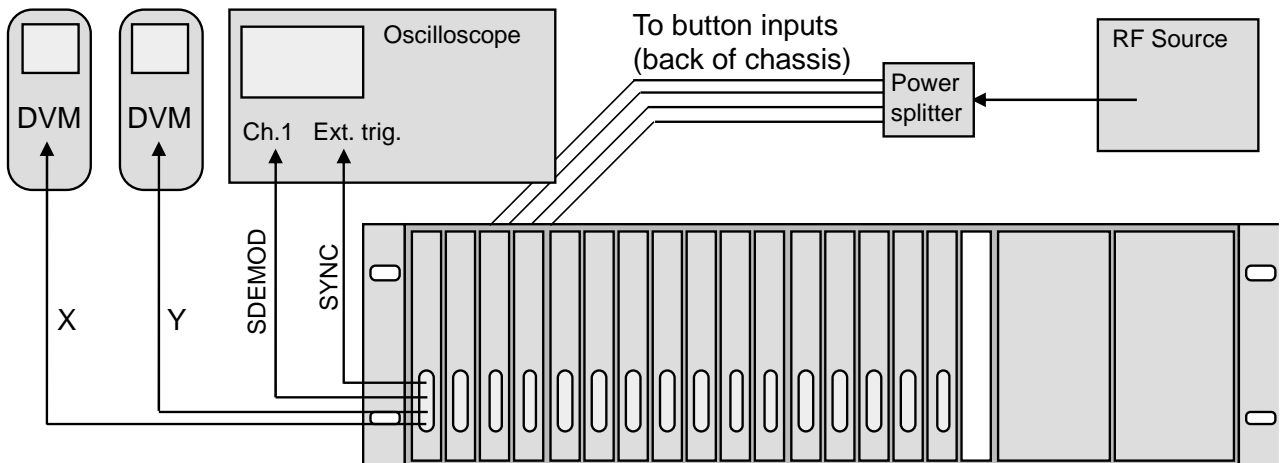

Attach the equipment together as shown above.

Set the oscilloscope time base on 0.2 ms / div.
 Ext. trigger connects to SYNC signal, trigger level 0.2V, 1 MΩ AC coupling
 Channel 1 to SDEMOD signal, sensitivity 0.1 V / div., 1 MΩ AC coupling

Set the RF source to the operating frequency.
 Amplitude ca. -13 dBm

Note: The BPM module operating frequency is written on the F-Key daughter board.
 To access the F-Key, remove the BPM module shield.

Set the X and Y voltmeters range in such a way that millivolts are readable.
 Connect to AC mains, the oscilloscope should display:

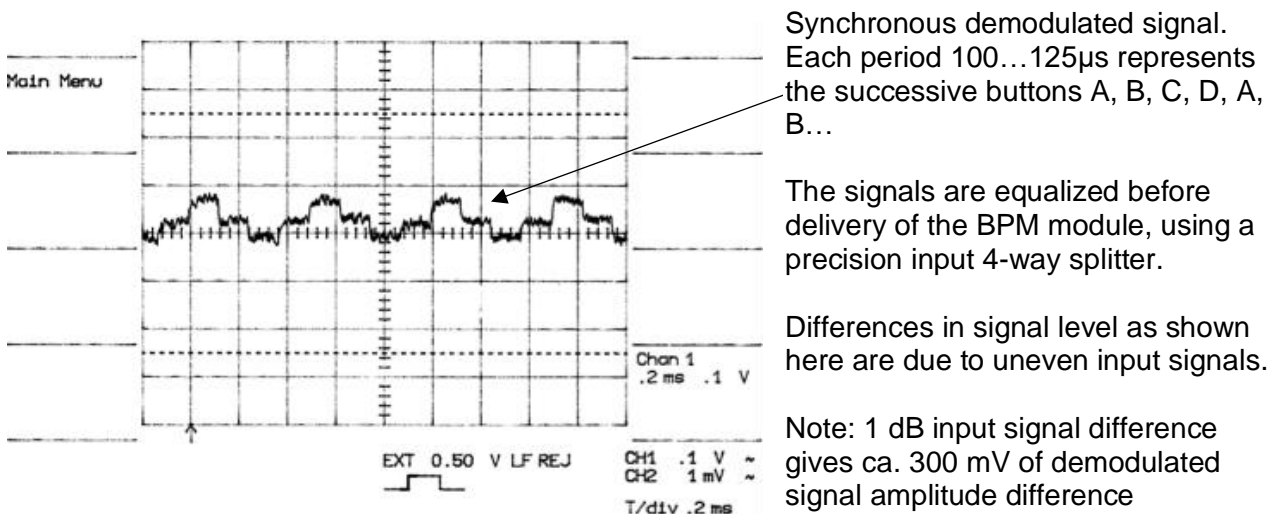

It may be that the demodulated button signals are uneven, like this:

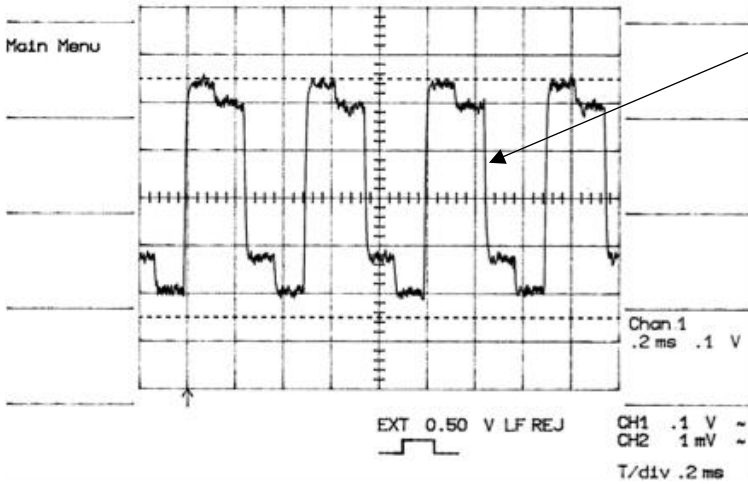

Synchronous demodulated signal.
Each period 100...125 μ s represents
the successive buttons A, B, C, D, A,
B...

This demodulated signal indicates
large difference of power applied to
the button inputs.

Differences in signal level as shown
here exceed 1 dB.

The on-board button attenuators could be adjusted to compensate for the input power difference, therefore equalize the signals, but...

Do not readjust the on-board attenuators before you are familiar with the BPM behavior.

What if the display does not look as shown?

Check that all DIP switches of the table-top test kit are set OFF (left position).
Check that all cables are properly connected.
Check that the RF source gives the required frequency and amplitude.

If you have more than one BPM module, try another one.

Getting familiar with the BPM

Vary the power from the RF source to simulate beam intensity variations.
Explore the range from 0 dBm down to -90 dBm.
Remember that the 4-way power splitter absorbs some power: adjust for it!

While the RF source output power is changed, observe the intensity dependence of X and Y outputs on the voltmeters. If the BPM electronics gain has been set for 1 V/mm, each mV is equivalent to 1 μm beam displacement.

Measure the rms noise at various signal levels.
Observe the noise spectrum with an FFT or baseband spectrum analyzer, at various signal levels.

ON-BOARD ATTENUATORS ADJUSTMENT

Introduction

The BPM module is equipped with four on-board adjustable attenuators. Each attenuator adjustment range exceeds 1 dB.

The BPM electronics has best performance, i.e., more linearity over the dynamic range, when the power difference between input signals is kept to a minimum. This is obtained for a centered beam and cables with equal attenuation.

The on-board attenuators can be used –within their limited 1 dB range– to compensate for an off-centered beam or unequal cable attenuations.

Please contact Bergoz Instrumentation if you need to adjust the on on-board attenuators

BUTTON SAMPLING

The BPM module has an on-board clock to drive the input multiplexer. The internal clock frequency is adjustable by the “Clock adjust” potentiometer from 8 to 10 kHz.

Each button is thus sampled during 100 to 125 μ s, and a complete scan is made in 400 to 500 μ s.

The beginning of each scanning cycle is available as output signal SYNC rising edge (See “Connector Pins Allocation”, this manual). SYNC frequency is $\frac{1}{4}$ of sampling frequency.

The internal clock can be overridden by an external clock.

EXTERNAL CLOCK

An external clock can be applied to the BPM module to drive the input multiplexer.

It must be applied to CLK* (See “Connector Pins Allocation”, this manual).

Amplitude $\geq 6V_{p-p}$, or $\geq 3 V$ positive-going, pulse length $\geq 10\mu s$.

It overrides the internal clock after a few milliseconds.

The BPM module operates properly up to an external frequency of 40 kHz. Therefore, the sampling of each button input can be made in $25\mu s$, the four buttons can be sampled in $100\mu s$. As a result, the beam position can be effectively sampled up to a frequency of 10 kHz.

The use of an external clock –and faster beam position sampling– may be required to eliminate aliasing of certain beam motions.

The performance of the BPM module is not affected by a higher sampling frequency:

- The X/Y output noise increase is not noticeable
- The X/Y zero (on-center) dc values are slightly shifted, but stable at each particular frequency.

ALGORITHM & POLARITY CONVENTION

45° buttons

$$X = K_x \frac{V_A - V_B - V_C + V_D}{V_A + V_B + V_C + V_D}$$

$$Y = K_y \frac{V_A + V_B - V_C - V_D}{V_A + V_B + V_C + V_D}$$

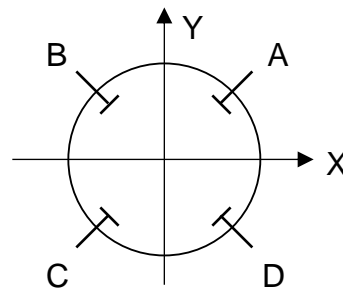

Orthogonal buttons

$$X = K_x \frac{V_A - V_C}{V_A + V_B + V_C + V_D}$$

$$Y = K_y \frac{V_B - V_D}{V_A + V_B + V_C + V_D}$$

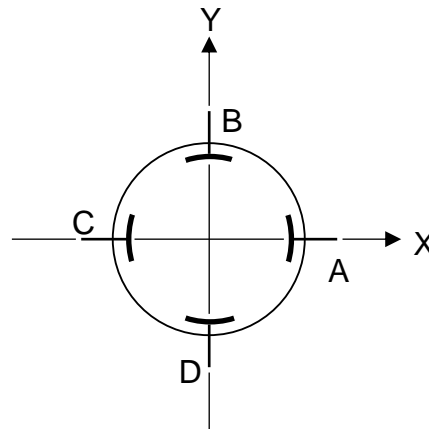

PRINCIPLE OF OPERATION

The signals from the BPM buttons are time-multiplexed into a single signal applied to a superheterodyne receiver. The demodulated signal is demultiplexed into four button values stored in analog memories. The four signals are summed, and the sum is maintained constant by an automatic gain control. The sum of all buttons being equal, the beam position is obtained by the analog summations $X=A-B-C+D$ and $Y=A+B-C-D$ for 45° buttons, and $Y=D-B$ and $Y=A-C$ for orthogonal buttons.

Papers giving more details can be found on our website:
www.bergoz.com :: MX-BPM :: Downloads :: Papers

- Precision Analog Signal Processing for Beam Position Measurements in Electron Storage Rings, J.A. Hinkson and K.B. Unser, Proceedings of the 2nd DIPAC, Travemünde 1995
- New Generation Electronics Applied to Beam Position Monitors, Klaus B. Unser 1996 Beam Instrumentation Workshop, Argonne National Laboratory.

Many of the fundamental principles of our BPM module were developed by John W. Bittner and Richard W. Biscardi for the National Synchrotron Light Source at Brookhaven National Laboratory. U.S. Patent 5,001,416 was granted to them on March 19, 1991.

BLOCK DIAGRAM

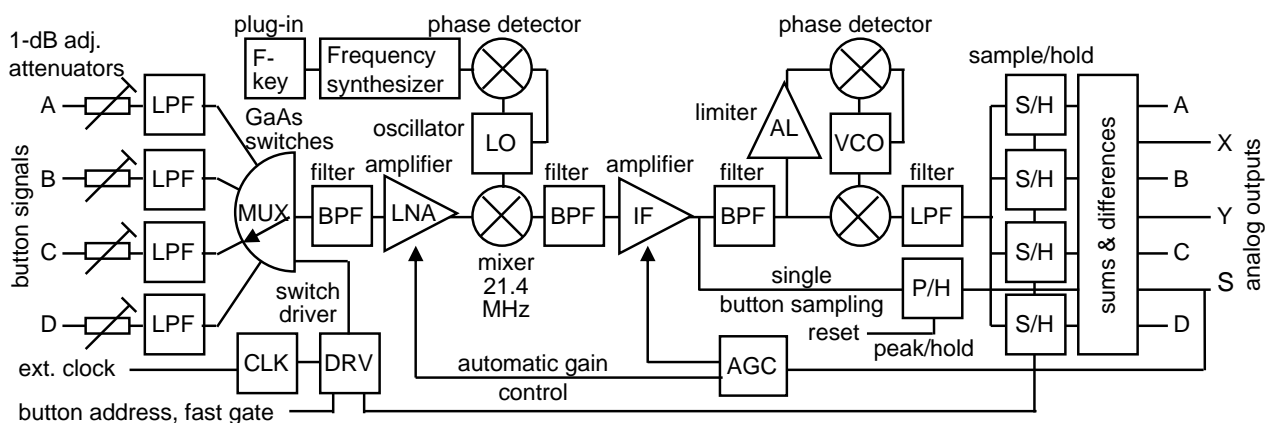

PERFORMANCE

BPM electronics for closed orbit measurement are characterized by:

- Sampling frequency of the button signals
- Output signal noise (resolution) vs. input signal strength
- Dynamic range of signals that may be applied to the unit, itself characterized by:
 - Position error (linearity) vs. input signal strength for equal signals (on-center beam)
 - Position error (linearity) vs. input signal strength for unequal signals (off-center beam)
 - Drifts caused by environmental changes

The performance of the first regular production units is given hereafter:

Sampling frequency

Up to 40 kHz. X and Y are updated at the rate up to 10 kHz. With the internal (default) clock, the sampling frequency is 2...2.5 kHz.

Output signal noise (resolution) vs. input signal strength

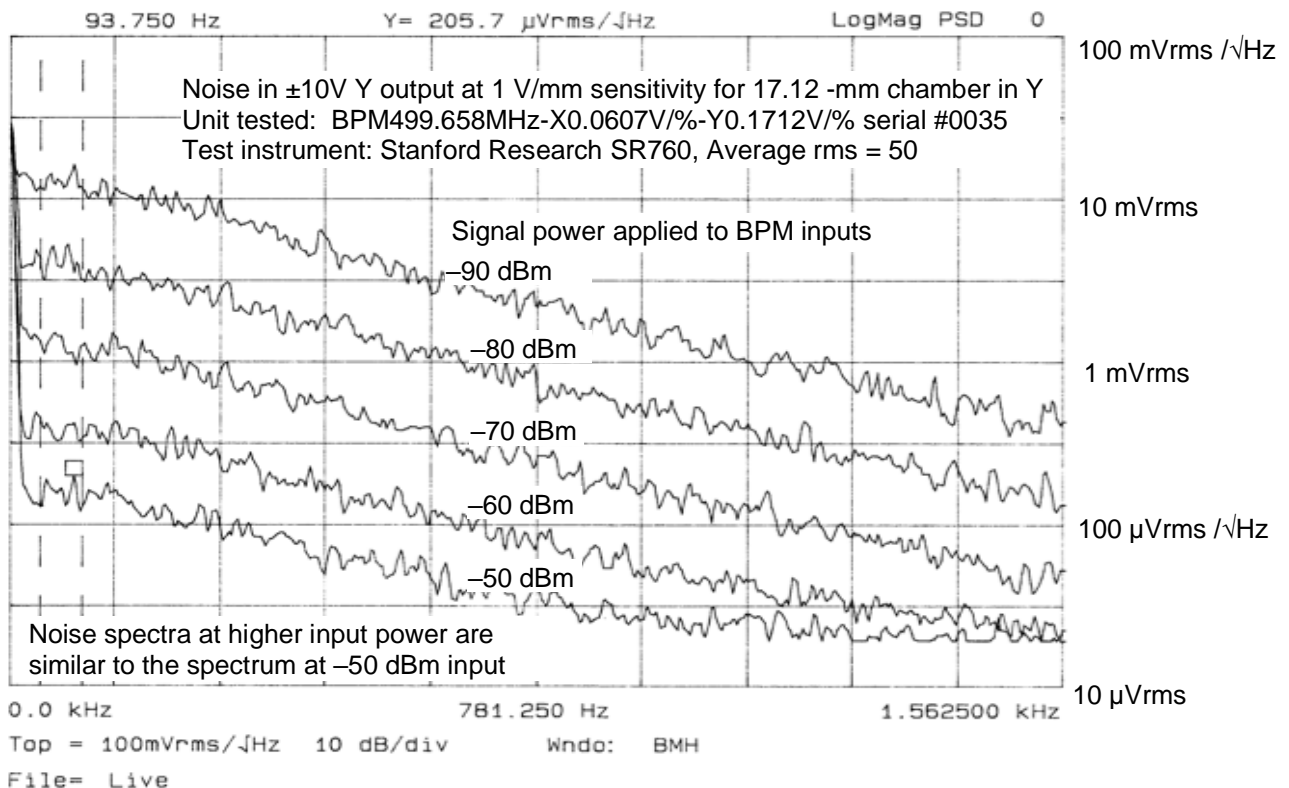

Position error (linearity) vs. input signal strength

Front Panel

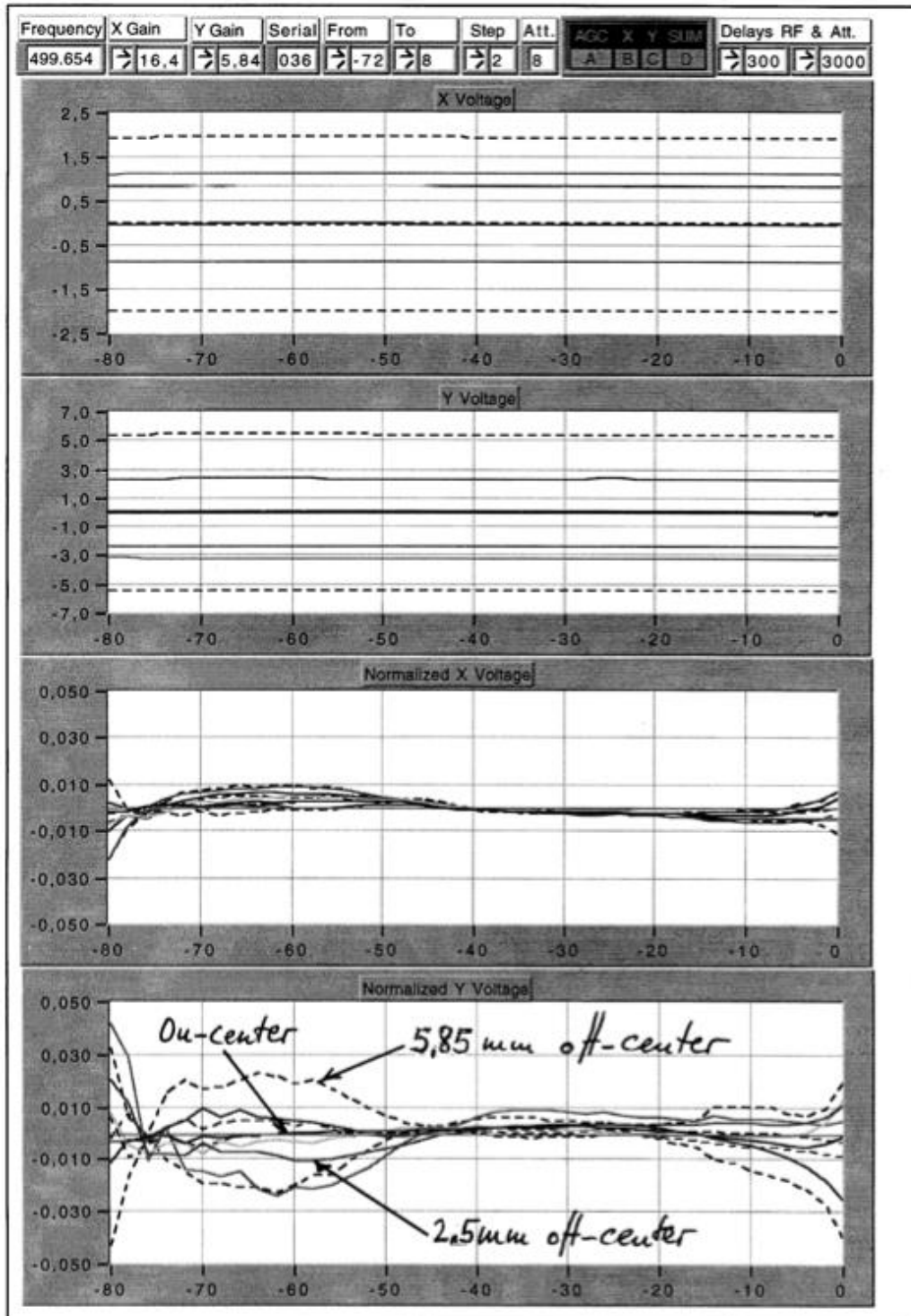

LabVIEW data acquisition virtual instrument using NB-MIO-16XH sampler, by Karen Scott

Temperature drift

DRIFT of the X output
Cold start
9 hours recording
Day/Night temperatures
Min. = 19.4°C
Max. = 25.3°C

Unit tested:
LNLS Campinas, serial #020
BPM-476.003MHz-X0.21V/%-Y0.21V/%
Date: Apr. 29, 1996, by Alain Charvet

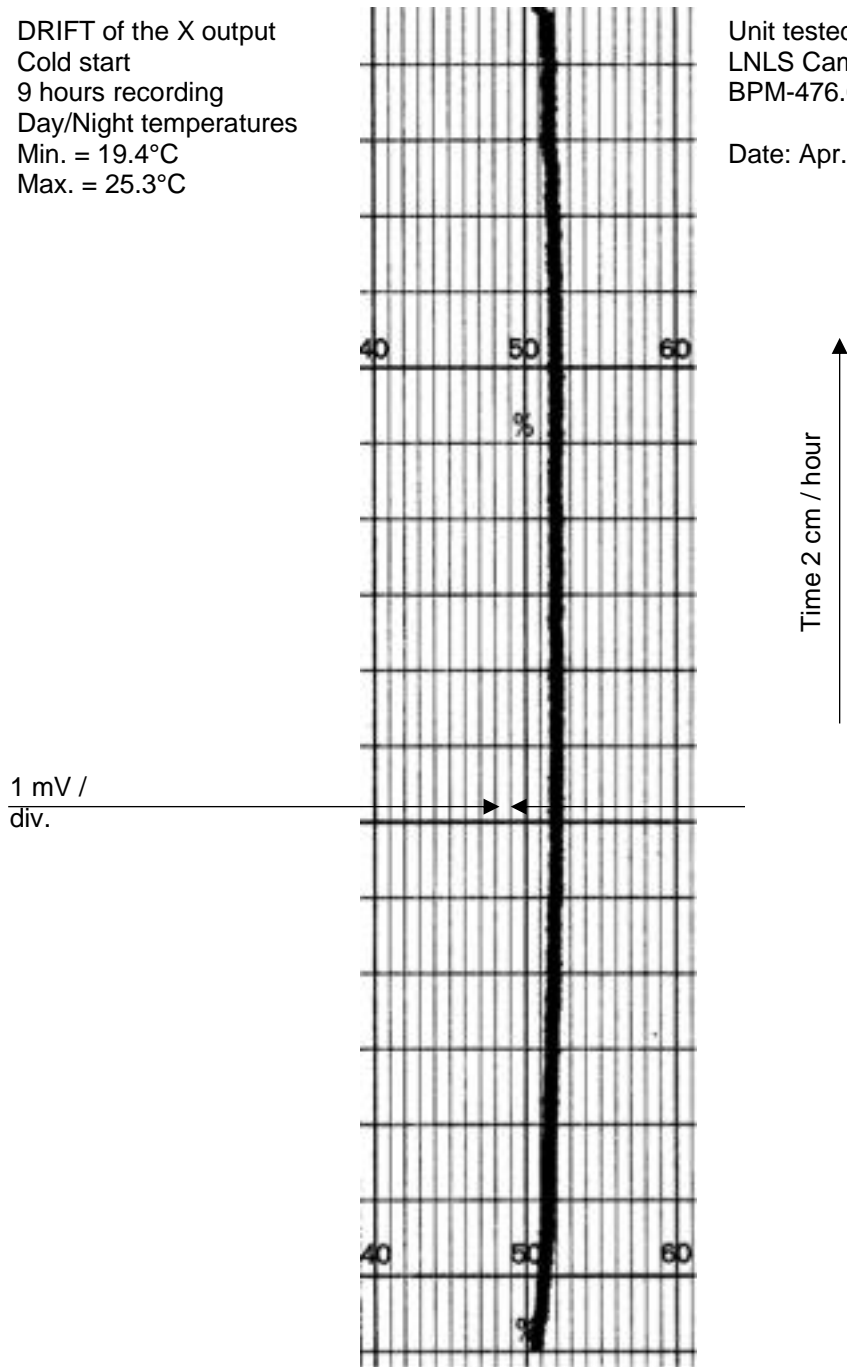

CLOSED ORBIT OPERATING MODE

This is the simplest operating mode. It is the default mode, i.e. when no external control signals are applied to the BPM module.

In the default mode, the internal clock controls the button sampling frequency (8...10 kHz).

The average beam position is available as:

XOUT X output. Analog output. (See Algorithm & Polarity Conventions, this manual)
Voltage range: $-10V...+10V$. Zero is centered beam.

YOUT Y output. Analog output. (See Algorithm & Polarity Conventions, this manual)
Voltage range: $-10V...+10V$. Zero is centered beam.

The value of each individual button A, B, C and D is also available. They can be used to compute –externally– the beam position with algorithms other than Δ/Σ :

AOUT A output. Analog output.
Voltage range: $0...+10V$. Pedestal ca. 1 V.

BOUT B output. Analog output.
Voltage range: $0...+10V$. Pedestal ca. 1 V.

COUT C output. Analog output.
Voltage range: $0...+10V$. Pedestal ca. 1 V.

DOUT D output. Analog output.
Voltage range: $0...+10V$. Pedestal ca. 1 V.

In closed orbit mode, the BPM module performance can be monitored with:

PLLOCK PLL demodulator in lock & good signal level. TTL output.
High = PLL in lock and signal level OK
Low = PLL out of lock or signal level poor

The DB9 female front-panel connector allows the observation of the multiplexed demodulated signal:

SDEMODO Synchronous demodulator output. Analog output. For oscilloscope viewing.

SYNC Synchronization pulse. TTL output. Positive-going. For oscilloscope trigger.

The on-board local oscillator frequency synthesizer uses an MB87003A circuit from Fujitsu. It requires a 17-bit serial word for its programming¹. The BPM module implementation of this circuit is described in an annex to this manual².

Changing the LO frequency

The LO frequency has been adjusted before shipment.
It can be adjusted upon request to Bergoz Instrumentation.

¹ Fujitsu Telecommunications Products, 1992 data book, Cmos PLL frequency synthesizer, page 2-3 thru 2-14

² New Generation Electronics Applied to Beam Position Monitors, K.B. Unser, page 4, Tbp.: proceedings of the 1996 Beam Instrumentation Workshop, Argonne.

SIGNALS

Button Inputs

BUTA Button inputs A, B, C, and D. Impedance 50Ω.
BUTB See Algorithms & Polarity Conventions, this manual, for buttons assignment.
BUTC
BUTD

Auxiliary fast signals

RFOUT RF signal output. Reserved for future use.

LOIN Input for external Local Oscillator. On option only. Nominal power 0 dBm, range -8 dBm...+6 dBm. Internally terminated in 50 Ω. External Local Oscillator option not compatible with on-board LO.

GATE External fast NIM gate. Only with option BPM-FG. Multiplexer GaAs switch closes only during GATE. GATE is NIM signal -20mA in 50Ω load. Gate width ≥ 20 ns.

Common external controls

Common external controls are controls which are common to all BPM modules in a BPM chassis.

Note: When no external controls are applied, the BPM default mode is:

- Closed orbit measurement
- Sampling frequency as given by the internal clock
- Automatic gain control

SBS* Single Button Sampling mode. TTL input.
 Default value: high = SBS mode not enabled.

BADD0* Button addresses. TTL input. Active only when SBS mode is enabled.

BADD1*	BADD1	BADD0
Button A	high	low
Button B	low	low
Button C	high	high
Button D	low	high

Default value: Button C

PHRESET* Peak and Hold Reset. TTL input.
 pull down to reset
 Reset pulse duration ≥ 10 ms
 Reset pulse must terminate at least 1 ms before the bunch to be measured.
 Default value: high

- AGCD*** AGC disable. TTL input. Disables the Automatic Gain Control (on option only)
Pull down to disable AGC.
Default value: high.
- CLK*** External sampling clock, input, overrides the internal clock after a few milliseconds when applied.
Maximum frequency 40 kHz
Amplitude ≥ 6 Vpp, or ≥ 3 V positive-going
Pulse length ≥ 10 μ s
Default value: the internal clock is active.
- GND** Ground for external controls.

Input and output signals

Input and output signals hereafter are specific to each BPM module, contrary to the above Common external controls which are shared by all BPM modules in a BPM chassis.

- GND** Analog ground for outputs
- PLLOCK** PLL demodulator in lock & good signal level. TTL output.
High = PLL in lock and signal level OK
Low = PLL out of lock or signal level poor
- VAGC** Automatic Gain Control voltage. Analog output. Used for production tests.
Voltage range +4V...+8V when PLL in lock.
- XOUT** X output. Analog output.
Voltage range: -10 V...+10V. Zero is centered beam.
Output impedance: 100 Ω
Driving capability: 10 mA
When BPM-SBS option is installed and SBS* is low,
XOUT is analog output value of button addressed, from P/H circuit
Voltage range 0...+5V, pedestal ca. 0.5 V.
P/H circuit is reset by PHRESET* low.
- YOUT** Y output. Analog output.
Voltage range: -10 V...+10V. Zero is centered beam.
Output impedance: 100 Ω
Driving capability: 10 mA
- SOUT** Analog sum of A, B, C and D signals. Analog output. Used for production tests.
Voltage is maintained by AGC at fixed value in range -3 V... -4 V

AOUT	<p>A output. Analog output. Voltage range: 0...+10V. Pedestal ca. 1 V. Output impedance: 1kΩ Driving capability: 1 mA</p>
BOUT	<p>B output. Analog output. Voltage range: 0...+10V. Pedestal ca. 1 V. Output impedance: 1kΩ Driving capability: 1 mA</p>
COUT	<p>C output. Analog output. Voltage range: 0...+10V. Pedestal ca. 1 V. Output impedance: 1kΩ Driving capability: 1 mA</p>
DOUT	<p>D output. Analog output. Voltage range: 0...+10V. Pedestal ca. 1 V. Output impedance: 1kΩ Driving capability: 1 mA</p>
SYNC	<p>Synchronization pulse. TTL output. Positive-going. For oscilloscope trigger. Rising edge marks the beginning of button A sampling sequence. Remains high during button A sampling cycle; down during B, C and D. SYNC frequency is 1/4 of sampling frequency, also when external clock CLK* is active.</p>
SDEMOD	<p>Synchronous demodulator output. Analog output. For oscilloscope viewing.</p>
PDEMOD	<p>Peak demodulator output. Analog output. Reserved for future use.</p>
GAIN	<p>External gain setting. Analog input (on option only). Voltage range: >0...<+10V. Active only when optional signal AGCD* (AGC disable) is pulled down.</p>

BPM CABLES LAYOUT, INSTALLATION

A button signal amplitude difference of 0.00043 dB

....changes the BPM output by 1 mV = 1 μm.

This is equivalent to 2.5mΩ change in connector contact resistance!

Conditions: 20-mm vacuum chamber calibration factor, 1 V/mm BPM system sensitivity, 50Ω cable

Cable layout

Unnecessary intermediate connectors should be avoided. When for practical reasons patch-panels must be used, the cables on either side of the patch-panel should be passed through tubular ferrite cores. Ferrite material must have high permeability at the BPM operating frequency.

The four cables pertaining to the same BPM stations must be laid side by side. Cables, BPM chassis and modules should be kept away –as much as possible– from RF equipment, klystrons, cavities.

Connectors must be chosen carefully to match the cable used. Connectors manufacturer’s instructions must be followed meticulously. If cable layout is subcontracted, subcontractors must be informed of the extreme reliability expected from these cables. All cables with connectors must be checked before installation with a network analyzer, up to twice the operating frequency at least; i.e., up to 1 GHz for 500 MHz operating frequency.

BPM modules must be installed in an RF-shielded chassis.

Note: Unlike most BPM electronics, the BPM module does not require the button signal to be in phase. Cables do not need to be phase-adjusted. The BPM module tolerates any phase change, even 180°.

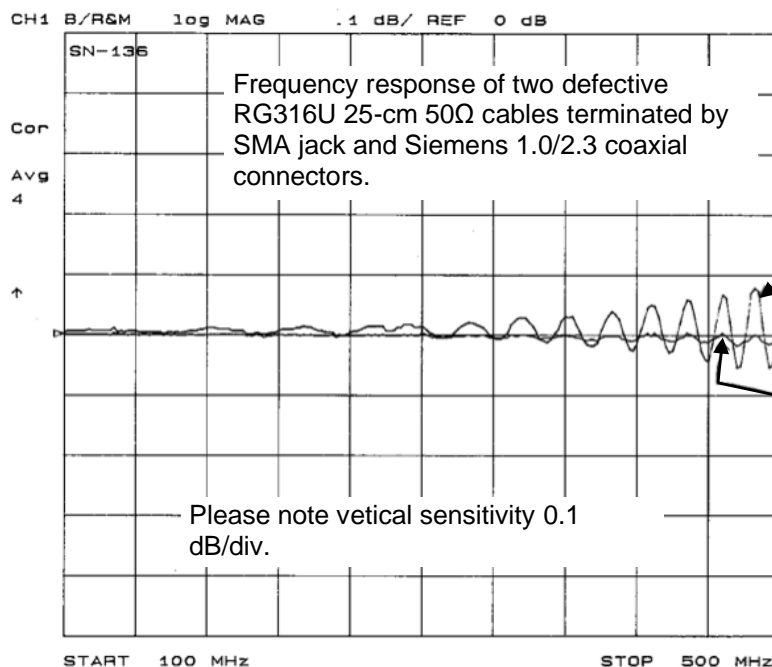

Defective cables examples

A close examination of this cable showed that 7 wires of the cable braid had been cut when the SMA connector was fitted. The cable braid has a total of ca. 60 wires.

Close examination of this cable did not reveal anything suspect. Yet, 9 cables out of 302 exhibited this particular behavior

Good cables exhibit a frequency response within ±0.01 dB up to 1 GHz

OPERATING CONSIDERATIONS

BPM aliasing of AM and FM modulations

Aliasing by the BPM can indicate nonexistent beam motions. Both FM and AM modulations of the RF signal can cause aliasing. No matter which button sampling frequency is chosen, aliasing will appear at a certain modulation frequency.

Aliasing occurs because the beam sampling frequency is lower than the other frequencies involved.

Some of the frequencies come from the beam:

- all harmonics of the revolution frequency, thus,
- the RF frequency extending to the full frequency spectrum of the bunches,
- the betatron and synchrotron frequencies.

More frequencies are produced by the BPM module itself:

- the local oscillator frequency and its harmonics,
- the original frequency of the quartz,
- the prescaling dividers of the frequency synthesizer.

These frequencies are voluntarily mixed together in the superheterodyne mixer and produce every possible sum and difference. Most of them will be eliminated by filters, but some of them are so close to the intermediate frequency that they cannot be eliminated.

Finally, the BPM sampling process –at the frequency of the clock– will produce signal aliasing.

Any of these frequencies in the range 0 to 1 kHz will appear as a spectral line in the BPM outputs (X, Y, A, B, C and D).

Identifying and eliminating aliasing

The BPM output (X, Y or both) must be observed with a low frequency spectrum analyzer or FFT analyzer in the 0 to 2-3 kHz bandwidth.

First, check the BPM with an RF generator. Apply the RF generator signal to the BPM module via a 4-way splitter (see page 4, this manual). The BPM noise spectrum should look as printed on the Noise vs. frequency hardcopy shipped with the calibration certificate.

Then, connect the BPM to the beam position pick-ups. If spectral lines (noise peaks) appear in the spectrum, several actions can be attempted to eliminate them.

Note: It is possible that one BPM module exhibits those spectral lines, while other BPM modules do not. This is because the local oscillator frequency and the clock frequency is not exactly the same for all BPM modules.

- a) The sampling clock frequency can be changed.
- b) The local oscillator frequency can be changed by a few thousand Hertz
- c) The local oscillator frequency can be changed in large steps by changing the synthesizer's F-key, yet this will generally not be necessary. (see "F-key" page 7, this manual, for its location, page 20 for its programming)

It is recommended to start with the sampling clock. The on-board clock generator frequency can be adjusted over a small range (ca. $\pm 20\%$) with the "Clock adjust" potentiometer (see "Button Sampling", page 7, this manual). For a wider range, the on-board clock can be overridden by an external clock signal (see "External Clock", page 8, this manual).

By increasing the sampling clock frequency, it may be possible to "push" the spectral lines (noise peaks) out of the 0...1 kHz bandwidth of BPM response.

Note: When the external clock signal is applied to the BPM module thru the DB9 male connector (pin 8) at the rear panel of the BPM-RFC chassis, it overrides the clock for all the modules in the chassis.

If the spectral lines cannot be pushed out of the 0...1 kHz bandwidth, or if it is not desirable to change the sampling clock frequency, then the local oscillator (LO) frequency can be changed.

This will work only if LO intermodulation is at the origin of the spectral line. To test this hypothesis, install the BPM module out of the chassis on a card extender (see "Procedure", this manual).

Put your finger on the quartz crystal oscillator (The quartz is located next to the "Clock adjust" potentiometer). The LO frequency will change by a few hundreds of Hertz. Observe the output spectrum: if the spectral lines (noise peaks) move up or down in frequency, it may be possible to "push" those lines out of the 0...1 kHz bandwidth of BPM response.

More than 2 kHz LO frequency change can be obtained by installing a few-pf capacitor (C94) on the BPM board.

Aliasing was observed on ALS at LBL³ while using the LBL-built BPM prototype. Jim Hinkson suggests a diagnostic of aliasing and a cure: "We know the frequencies for synchrotron and betatron oscillations in our machine. These frequencies change with machine settings. It would be a simple matter to program a clock frequency based on tune measurements. This would allow us to avoid aliasing under all conditions. It's easy to see if aliasing is a problem.

Using a low frequency spectrum analyzer, coherent "beam" motion can be clearly seen in the sub-micron range. If aliasing is suspected, all one needs to do is change the clock frequency and see if the spectral line moves. If it does, it's aliasing."

³ Jim Hinkson, private communication, June 1995

CONNECTORS PINS ALLOCATION Rev. 4.0

Connectors on Chassis BPM-RFC/X					
BPM Module rear connector					
DB9 female front panel connector					
BUTTON INPUTS					
Button A	BUTA			b2 *	
Button B	BUTB			b5 *	
Button C	BUTC			b8 *	
Button D	BUTD			b11 *	
AUXILIARY FAST SIGNALS					
Fast gate	GATE			b22	
Reserved (RF signal out)	RFOUT			b25	
Reserved (Local oscillator)	LOIN			b28	
Not allocated	free			b31	
					DB9 male
COMMON EXTERNAL CONTROLS					
Single button sampling mode	SBS*			b17	2
Button address	Upper bit	BADD1*		b16	3
	Lower bit	BADD0*		c17	4
Reset (single button mode)	PHRESET*			b15	5
AGC disable	AGCD*			b13	7
Sampling clock (inhibits on-board clock)	CLK*	6		c16	8
Reserved	free			a19	
Ground	GND			c14	9
Reserved				b18	1
					DB15 female
INPUT AND OUTPUT SIGNALS					
Ground (signal ground for all outputs)	GND	5		a20	15
PLL demodulator in lock output	PLLOCK			a13	1
AGC voltage output	VAGC	3		c19	2
X (also button value in single button mode)	XOUT	4		c20	3
Y output	YOUT	8		b19	4
Σ output	SOUT			b20	5
A button signal output	AOUT			a17	6
B button signal output	BOUT			a18	7
C button signal output	COUT			a15	8
D button signal output	DOUT			a16	9
Synchronization from sampling clock	SYNC	9		b14	10
Synchronous demodulator output	SDEMOD	7			
Peak demodulator output (single button mode)	PDEMOD	1			
External gain setting input	GAIN	2		a14	13
POWER SUPPLY					
+ 15 V	+15V			c13	
- 15 V	-15V			c15	
0 V (power supply ground)	GND			c14	

BPM CHASSIS

Description

The BPM-RFC/X chassis is built around a 19" Schroff rackable RF chassis.

Dimensions of the bin: 3U x 84F

Schroff reference: Europac Lab HF/RF #20845-283

The BPM-RFC/X is available equipped for 1 up to 16 BPM stations. X being the number of stations.

BPM-RFC/X with less than 16 stations are partially equipped BPM-RFC/16. As a result, all BPM chassis are field-upgradable to the full 16-station chassis.

Chassis rear view

DB9 male External controls input connector. Common to all stations

SMA jack RF input for test station

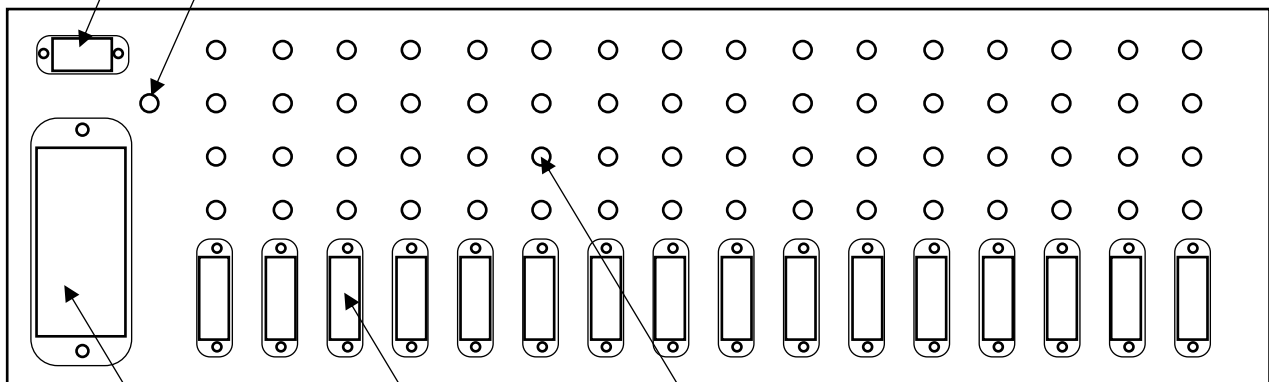

SMA jack A to D button inputs, 4 per BPM station, A on top

DB15 female BPM station output connector, one per BPM station

IEC male connector for AC mains

SPECIFICATIONS

BPM module

Beam intensity range	> 75 dB
Input signals	+5 dBm...–70 dBm, 50Ω
Operating frequency	According to order code
Noise rms	< 2mV [0...1 kHz] in ±10V @ +5 dBm < 5mV [0...1 kHz] in ±10V @ –35 dBm < 50mV [0...1 kHz] in ±10V @ –60 dBm
Linearity error	On-center: <5 mV [+5 dBm...–35 dBm] 2-mm off: <20 mV [+5 dBm...–35 dBm]
Sensitivity	User's choice. 1 V/mm recommended
X and Y gain	According to order code
Buttons sampling	2...2.5 ksamples/s with internal clock Up to 10 ksamples/s with external clock
Local oscillator	Factory-set frequency
Intermediate frequency	21.4 MHz or 10.7 MHz for narrow band IF
Outputs	X: ±10V, A–B–C+D, or A–C Y: ±10V, A+B–C–D, or B–D Σ: A+B+C+D, constant value (≈3V) A, B, C and D: >0...<+10V, ca. 1 V pedestal
Front panel LED	PLL in lock
Single button sampling	Enable and Reset TTL controls
Button address	Two TTL addressing lines
Single button output	Output on "X": >0...<+5V, pedestal ≈0.5V
Fast gate	NIM (50Ω negative-going –16mA pulse)
Power supply:	+ 15V, <200 mA (<250 mA with SBS option) – 15V, <40 mA (<60 mA with SBS option)

Power Supply module

AC mains voltage	Autoranging 98...132Vac and 185...265Vac with automatic range changeover
Power derating	No derating down to 85 Vac (at full chassis load)
Output	± 15 V, unequal loading tolerant
Power	75 W
Efficiency	84% at 220Vac 81% at 110 Vac
Inrush current	limited to 10A max.
Dimensions	per DIN41494: 3U high, 8F wide, 160mm deep
Manufacturer	Delta Elektronika BV, the Netherlands
Model	75 SX 15-15

BPM MODULE REAR CONNECTOR DIN41612M 24+8

Note: For connections, See Connector Pins Allocation, this manual.

BPM chassis for 1 up to 16 BPM modules are part of Bergoz Instrumentation sales program (BPM-RFC/X) and include the necessary mating connectors (See BPM chassis, this manual).

More information and latest manuals revisions can be found on our website

www.bergoz.com

If you have any questions, feel free to contact us by e-mail

info@bergoz.com

